

X-RAY / LASER POWER CENTERS

■ Applications

Single and three phase systems

■ Power Distribution

- Loadcenter available for plug-on or bolt-on circuit breakers
- Lug-to-Lug circuit breakers

■ Control Device

Programmable Logic Controller (PLC), Local and/or Remote Control Stations for up to 12 single receptacles

■ Mounting

Available for flush or surface mounted applications

■ Advanced Technology

The BENDER LIM2000plus™ series Line Isolation Monitor (LIM) features self-test, self-calibration and optional load monitoring

■ Standards

UL 1047 - Isolated Power Systems Equipment

■ Warranty

Industry's first 5 year limited warranty



X-RAY/LASER
POWER CENTERS

Introduction

ISOTROL Type XPC/LPC X-Ray/Laser Power Centers have been designed to selectively provide isolated power to the X-Ray and Laser receptacles within operating rooms and other electrically susceptible patient care areas. Designed in strict compliance with Underwriters Laboratories Standard UL1047, UL1022 and UL50, the XPC/LPC offers the most current technology for X-Ray/Laser isolated power distribution requirements.

General

The Type XPC/LPC typically includes a single or three phase transformer, a BENDER Line Isolation Monitor (LIM), a reference ground bus, a primary circuit breaker, branch circuit breakers, contactors, a selector station with momentary contact pushbuttons and built in indicating LEDs, and a Programmable Logic Controller (PLC). An alternate version of the Type XPC/LPC is controlled by a mechanically interlocked pushbutton station and is available upon request. The maximum number of branch circuit breakers is limited to twelve (12) plug-on or bolt-on.



Line Isolation Monitor
LIM2000plus™

Backbox

All backboxes are fabricated from 14GA galvanized steel. Surface mounted enclosures are finished with a coat of hospital ivory, epoxy enamel. Outline drawings shown on the following pages of this brochure provide additional dimensional and construction details.

Front Trim

Manufactured from 14GA Type 304 Stainless Steel with a #4 brushed finish, the front trim contains a door with hidden hinges and a flush mounted key lock that covers the load center. The front trim for flush mounted units extends 1" on all sides of the backbox. For surface mounted units, the front trim shall exactly match the dimensions of the backbox.

Isolation Transformer

Isolation transformers are available with various primary and secondary single and three phase voltages. Delta-Delta winding configuration is available for three phase applications. The transformer ratings are given on the isolation transformer data sheet found in ISOTROL's full catalog or by request.

Line Isolation Monitor (LIM)

The BENDER LIM2000plus™ series Line Isolation Monitor provides a digital / analog display. The LIM is available in single or three phase models with readout and response values of 2 or 5mA. The LIM2000plus™ has a patented measuring principle and is capable of detecting all combinations of capacitive and resistive faults, including balanced, unbalanced and hybrid faults. A self-test and calibration function is also featured. The LIM2000plus™ series LIM contributes less than 35mA to the Total Hazard Current (THC). Available options include load monitoring and RS485 communication. For further information see the LIM2000plus™ series data sheet.

Reference Ground Bus

The Type XPC/LPC X-Ray/Laser Isolated Power Center is provided with a twenty (20) point reference ground bus to satisfy equipotential requirements and for connection to remote ground jacks, master ground, patient ground, and receptacle ground modules.

X-Ray Equipment

A single XPC/LPC can serve single receptacles in several patient areas but requires that the receptacles and mating plugs are not interchangeable with the receptacles on the local IPS. The allowed receptacle configurations are:

- 2P/3W Grounding, 250V
- 3P/4W Grounding, 3ph, 250V

The rating of the receptacle must not exceed 60A for portable, mobile, and transportable medical equipment. The branch circuit rating is normally supplied by the manufacturer of the equipment is not to be < 50% of the momentary (≤ 5 seconds) rating or < 100% of the long-time (≥ 5 minutes) rating, whichever is greater. The "<100%" figure applies to therapeutic equipment.

When used to supply fixed and stationary medical equipment, a XPC/LPC panel must be located in the same OR or patient care area.



X-Ray/ Laser Receptacle Module

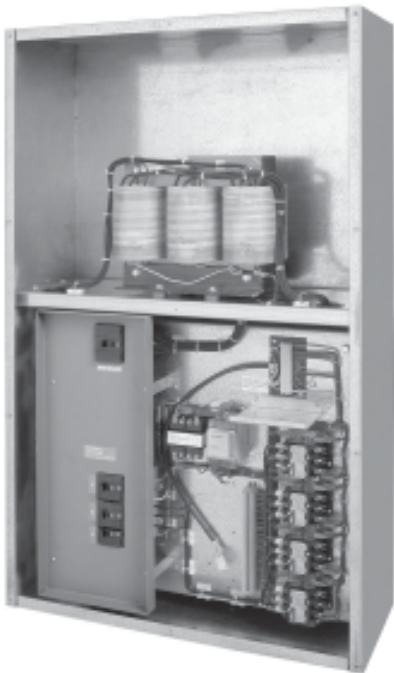

X-Ray / Laser
Power Center Interior

Circuit Configuration

A typical circuit arrangement is shown in the sketch on the next page. The XPC/LPC is comprised of a power and control section. For an X-Ray application, a single XPC can supply power to as many as twelve (12) X-Ray receptacle modules. The basic module contains a power receptacle only. It can be equipped with an "In-Use" lamp and a LIM remote indicator which duplicates the LIM function at the panel. The access door to the power receptacle can also be equipped with a limit switch that is used to lock-out power to the other receptacles. (See X-Ray/Laser Receptacle Module catalog section for more information)

The control section is designed around the use of a Programmable Logic Controller (PLC). Non PLC mechanically, interlocked control is also available.

Programmable Logic Controller (PLC)

The PLC has Input and Output (I/O) sections. Control wiring from pushbuttons, door switches, etc. are permanently wired into the input section.

Signals or contact closures from the output section can be used to actuate contactors, to apply power to a receptacle and an "In-Use" lamp, etc.

Software determines how the outputs respond to the inputs. This is the big advantage of a PLC since there are virtually an unlimited number of ways to connect the inputs to the outputs. Providing electrical interlocks is a simple matter. Changes can easily be made to the control logic without any changes in the field wiring. This flexibility is available from ISOTROL SYSTEMS at low cost and provides the end user with a tool that allows for future expansion.

Program changes, necessitated by expansion, can be downloaded from the factory.

Pushbutton Station

The Type RCS Remote Control Station with or without LIM remote indicator can easily be incorporated into a nurse station.

Support and Services

- On-site installation inspection and certification services
- System design assistance provided upon request
- Technical support hotline: (800) 833-6834

Outline Drawing for XPC/LPC Single and Three Phase 5 to 45kVA

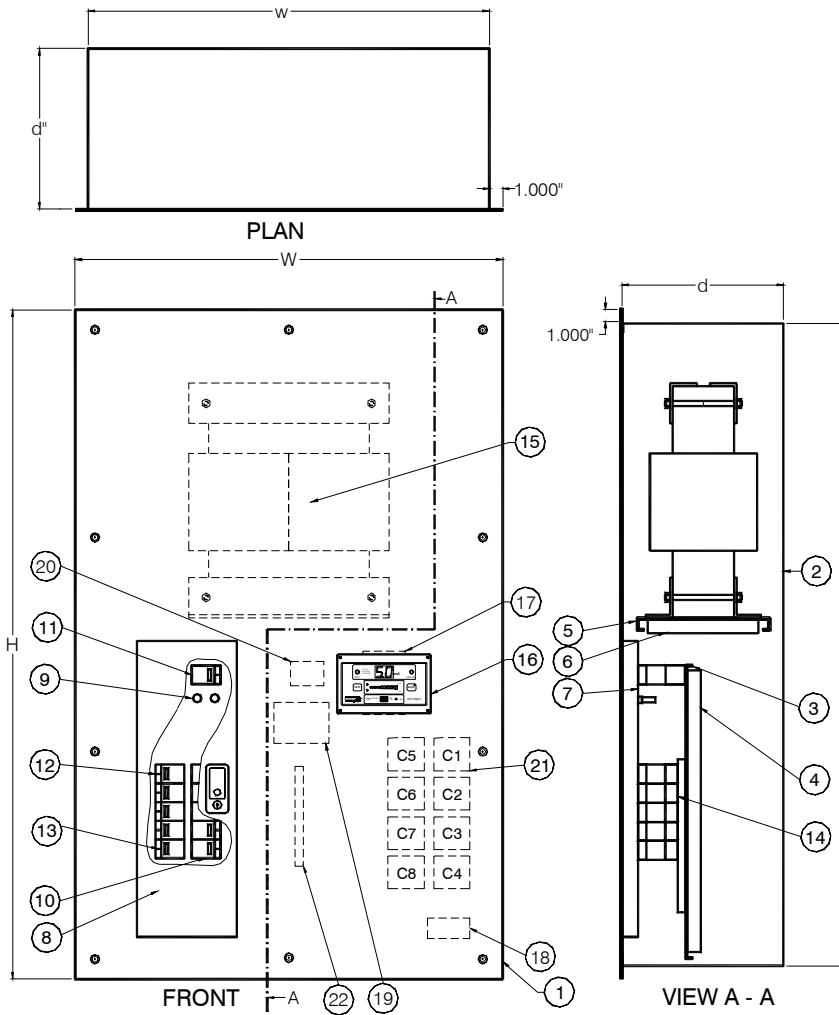

- 1 Stainless Steel Front Trim
- 2 Backbox, Galvanized Steel
- 3 Backplate, Galvanized Steel
- 4 Backplate Mounting Bracket
- 5 Transformer Shelf
- 6 Transformer Shelf Mounting Bracket
- 7 Circuit Breaker Deadfront
- 8 Stainless Steel Door w/Lock
- 9 LIM Fuses
- 10 LIM Circuit Breaker, 2P or 3P (Optional)
- 11 Main Circuit Breaker, 2P or 3P
- 12 Branch Circuit Breaker, 2P or 3P
- 13 Control Transformer Circuit Breaker, 2P or 3P
- 14 Loadcenter
- 15 Isolation Transformer, 1Ph or 3Ph
- 16 Line Isolation Monitor (LIM), 1Ph or 3Ph
- 17 LIM Connector Plate
- 18 Ground Bus
- 19 Programmable Logic Controller (PLC)
- 20 Control Transformer
- 21 Circuit Contactors (C1...C8)
- 22 Terminal Block

BACKBOX DESIGNATION	TRANSFORMER KVA SIZE	DIMENSION				
		h	w	d	H	W
C	5, 7.5, 10, 15, 20	48"	30"	12"	50"	32"
D	20, 25, 37.5, 45	48"	30"	14"	50"	32"

X-RAY / LASER POWER CENTER

Typical Circuit Arrangement for XPC/LPC

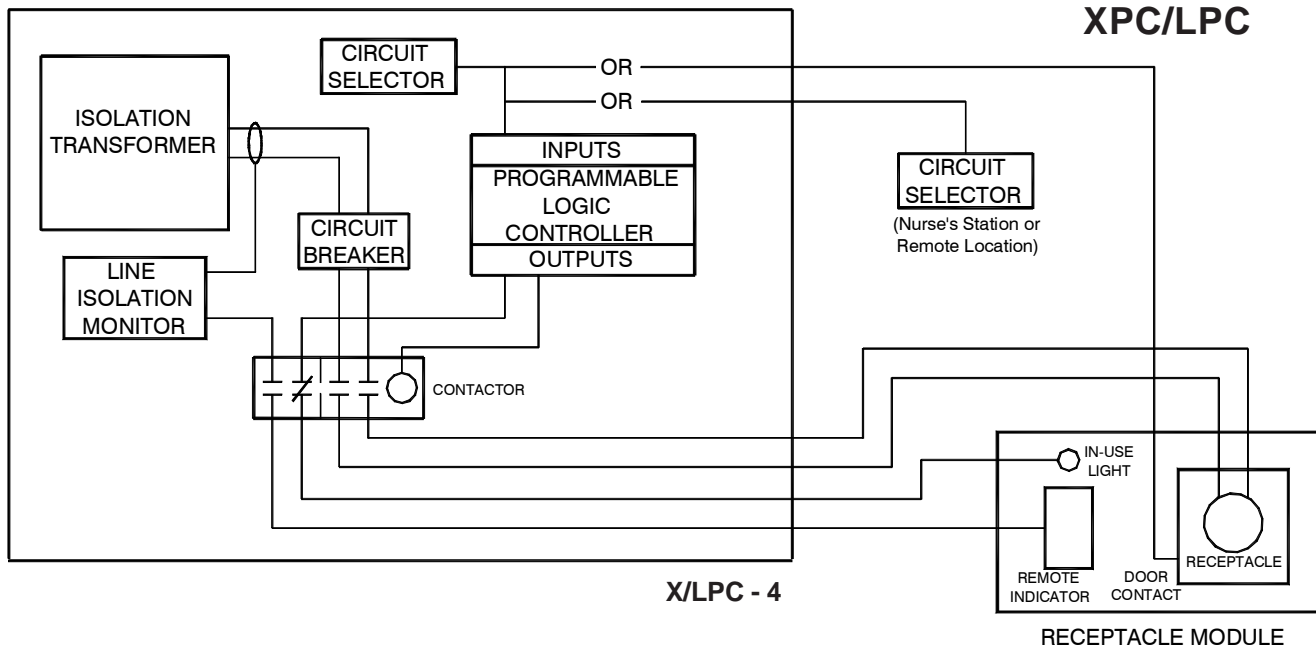

X/LPC - 4

RECEPTACLE MODULE

Selection Guide for X-Ray/Laser Power Centers (Type XPC/LPC)

When selecting the X-Ray/Laser Power Center for your application, use the Product Code below. If you have any questions or need further assistance, please call us using our toll-free number: (800) 833-6834.

Code A - Basic Designation

XPC: X-Ray Power Center LPC: Laser Power Center

Code B - Transformer Power Rating

5: 5kVA 7: 7.5kVA 10: 10kVA 15: 15kVA 20: 20kVA 25: 25kVA

X: Special kVA

Code C - Transformer Primary Voltage

A: 120V B: 208V C: 240V D: 277V
E: 480V G: 220V H: 110V X: Special Voltage

Code D - Transformer Secondary Voltage

A: 120V B: 208V C: 240V G: 220V H: 110V X: Special Voltage

Code E - Phases

1: 1 Phase 3: 3 Phase

Code F - Loadcenter - Manufacturer and Size

C1: Cutler Hammer	12 Positions Plug-On & Bolt-on	S1: Square D	12 Positions Plug-On & Bolt-On
C2: Cutler Hammer	16 Positions Plug-On Only	S2: Square D	16 Positions Plug-On & Bolt-On
CX: Cutler Hammer	Lug-to-Lug Circuit Breakers (No Loadcenter)	SX: Square D	Lug-to-Lug Circuit Breakers (No Loadcenter)
G1: General Electric	14 Positions Plug-On Only		
G2: General Electric	16 Positions Plug-On Only		
GX: General Electric	Lug-to-Lug Circuit Breakers (No Loadcenter)		

Code G - Quantity of Branch Circuit Breakers

Code H - Circuit Breaker Type

P: Plug-on B: Bolt-on L: Lug-to-lug

Code I - Number of Circuit Breaker Openings in Deadfront (Must be less than or equal to Loadcenter positions)

Code J - Quantity of Contactors

Any number between 2 and 16

Code K - Control Method

C: Programmable Logic Controller (PLC) I: Mechanically-Interlocked Pushbutton Station
X: Special

Code L - Control Operator For Panels with Control Method "C" and "X"

1: Remote pushbutton station
2: Door contacts with "In-Use" lamps at XRM/LRM
3: Door contacts without "In-Use" lamps at XRM/LRM
4: Pushbutton station at XPC/LPC
X: Special

For Panels with Control Method "I"

1: Remote pushbutton station
2: Pushbutton station at XPC/LPC

Code M - LIM Remote Indicator

0: None 1: LIM Remote without meter 2: LIM Remote with meter
3: LIM Remote with digital display

Code N - Backbox Sizes (Height x Width x Depth)

C: 48" x 30" x 12" D: 48" x 30" x 14" X: Special

Code O - Type of Mounting

F: Flush S: Surface

Call the factory for additional equipment or custom requirements

Example for ISOTROL Type XPC/LPC Product Code



Code A Code B Code C Code D Code E Code F Code G Code H Code I Code J Code K Code L Code M Code N Code O

Suggested Specification for ISOTROL Type XPC/LPC X-Ray/Laser Power Centers

Furnish and install ISOTROL Type XPC/LPC X-Ray/Laser Power Centers in the locations shown on the architectural/ electrical drawings. The XPC/LPC shall be UL Listed and labeled as an assembly. The Type XPC/LPC shall consist of the following:

Backbox

Shall be flushed or surface mounted as required, and shall be fabricated from 14GA galvanized steel. Surface mounted panels shall be finished with a coat of hospital ivory, epoxy enamel.

Front Trim

Shall be fabricated from 14GA Type 304 Stainless Steel with #4 brushed finish. The circuit breaker section shall be accessible through a door, with hidden hinges, that is flush with the front trim. The door shall contain a keyed flush lock that can be opened without a key when unlocked; all XPC/LPCs shall be keyed alike. The front trim shall contain a cut out for the Line Isolation Monitor (LIM) which shall remain visible at all times. The front trim for flush mounted units extends 1" on all sides of the backbox. For surface mounted units, the front trim shall exactly match the dimensions of the backbox. The front trim shall be attached to the backbox by a minimum of ten (10) #10-32 x 1" Stainless Steel Oval Head Phillips machine screws and ten (10) #10 Stainless Steel finishing washers.

Isolation Transformer

Shall be single or three phase, 50Hz or 60 Hz with primary and secondary voltages as indicated on the contract drawings. The transformer shall be manufactured using class H-rated insulation. It shall have an electrostatic shield between the primary and secondary windings which shall be grounded to the enclosure. The transformer core shall be a stacked design, securely clamped. Core and coil shall be vacuum impregnated, with a final wrap of insulating material. The core and coils shall be isolated from the enclosure by means of isolation mounts.

Total leakage current to ground from transformer secondary winding shall be in compliance with UL1047, Tables 30.1 and 30.2. Maximum sound level of transformer: 25dB for 5kVA units or less, 30dB for 7.5kVA units, 35dB for 10 & 15kVA units, and 40dB for 20 & 25kVA units. Temperature rise limited to 115 degree C above ambient under full load conditions. Transformer shall be UL Recognized as a component, for the voltages, amperage, and kVA rating required.

Line Isolation Monitor

Shall be a BENDER LIM2000plus™ series Line Isolation Monitor with a solid state modular assembly utilizing the dynamic principle of constantly monitoring the impedance between each circuit conductor and ground and shall provide a visual and audible indications of a first fault condition.

The LIM shall be capable of detecting all combinations of capacitive and resistive faults, including balanced, unbalanced and hybrid faults. The total hazard current shall be set at the factory to either 2 mA or 5 mA, and shall be field adjustable to either milliampere. The LIM shall contain a continuous reading

meter (digital / analog), an audible alarm device which shall sound in the event of of the system status. A green LED shall indicate "SAFE" status, a red LED shall indicate "HAZARD" status, and an amber LED shall indicate that the audible alarm feature is in the "MUTE" mode. A "TEST" button shall be provided so the functions of the LIM can be tested by hospital personnel. The meter, indicating lamps and "TEST" button shall all be flush with the face of the LIM and shall be protected by a rugged Lexan front foil. Remote indicator connections are also provided.

The LIM shall contain overload protection with an automatic reset feature. It shall be possible to order an optional RS485 communication port. The LIM shall be UL Recognized as a component.

Primary Circuit Breaker

Shall be two-pole or three-pole sized in accordance with NFPA 70(NEC) and UL1047 Standard based on the transformer primary voltage and kVA rating as shown on the contract documents and shall be full size, thermal magnetic type, minimum 10kAIC.

Secondary Branch Circuit Breakers

Shall two-pole or three-pole, ampacities, and quantities based on the contract drawings. Sized in accordance with NFPA 70 (NEC) and UL1047 Standard. Shall be full size and thermal magnetic type with a minimum 10kAIC.

Circuit Contactors

Provide up to twelve (12) circuit contactors which shall energize up to twelve (12) XRM or LRM X-Ray/Laser Receptacle Modules.

Circuit Selector

Provide one of the following circuit selectors:

- BENDER Type MK2010 pushbutton selector with momentary contact pushbuttons and built in LEDs mounted on the circuit breaker deadfront or Type RCS Remote Control Station.
- A mechanically interlocked push button station mounted on the circuit breaker deadfront
- Door switch (magnetic type, shall be UL Listed) on Type XRM / LRM, X-Ray / Laser Receptacle Module

Individual circuits are controlled by the PLC Programmable Logic Controller or mechanically interlocked pushbutton stations.

Programmable Logic Controller (PLC)

Shall provide up to 32 I/O ports and shall have the ability to store the programming for I/O configurations in case of a power failure.

Reference Ground Bus

Shall contain a minimum of one (1) #4-2/0 main lug and nineteen (19) #14-4 grounding lugs.

Specifications and other data subject to change without notice.

Our Address

BENDER/ISOTROL

700 Fox Chase

Coatesville, PA 19320

Phone: 800-833-6834

610-383-9655

Fax: 610-383-7100

E-mail: isotrol@bender.org

