

Remote Indicator for Line Isolation Monitor



MK2000M-G2 MK2000MP-G2



MK2000M-G2



MK2000MP-G2

- LED display for long life
- No interference with medical equipment
- Interfaces with all BENDER LIMs
- Interfaces with all other manufacturers LIMs
- Uses low voltage wiring (12V DC or 12V AC)
- Mounts to standard electrical 2 gang box
- Connection is by screw terminal strip
- Easy to clean rugged stainless steel and Lexan design

Product Description

Remote indicators are used with BENDER Line Isolation Monitors (LIMs) and are mounted in remote locations. A remote indicator duplicates audible and visible alarm indications of the LIM. The remote indicator contains a green "SAFE" LED, a red "HAZARD" LED, and a "MUTE" button with an integral amber LED. The "MUTE" button is used to silence the remote audible alarm (local muting). Optionally it can be used to silence all audible alarms in the system (system muting). An optional "TEST" button can remotely perform a function test of the LIM. The analog meter mimics the LIM hazard current display. The standard scale is graduated at 1.0 mA intervals.

The remote indicators MK2000M and MK2000MP are supplied as two-gang (G2) stainless steel faceplates for flush mounting into a panel or wall box with a 2" minimum depth. The basic electrical connection is made via five wires. See the wiring diagram on page 2.

Custom remote indicators and remote annunciator stations (RAS) are also available. For information see RAS brochure.

Operational Information

The remote indicators are controlled by a 12V DC signal from the LIM. The maximum current consumption is 40mA. A green "SAFE" LED stays illuminated while the system is in safe condition.

When the LIM goes into the alarm condition the hazard line is energized. The green "SAFE" LED extinguishes and the red "HAZARD" LED illuminates when the predetermined limit is exceeded. While in "HAZARD" the audible alarm will sound. When depressed, the "MUTE" button shall mute the audible alarm signal. Actuation of this button shall cause the integral amber LED to illuminate, indicating that the audible alarm has been silenced. When the leakage current has returned to the acceptable limit level, the alarm indicators shall automatically reset. The optional "TEST" button will put the LIM through the test cycle. The "TEST" button must be pushed momentarily to activate the test sequence of the LIM2000plus™. When using the MK2000 Series Remote with the IZ1490 Series Line Isolation Monitor, the "TEST" button must be held for approximately ten (10) seconds to complete the test.

Ordering Information

Type	Article No.
MK2000M-G2	923540
MK2000MP-G2	923541

Technical Data for MK2000M-G2 & MK2000MP-G2

Operating voltage	12V DC or 12V AC
Max. current	40 mA
Operation class	continuous operation
Ambient temperature	
when operating	+32° F to +122° F 0° C to +50° C
when stored	-13° F to +158° F -25° C to +70° C
Connection	screw terminal block
Max. conductor size	16 AWG stranded
Mounting	by screws
Weight	
MK2000M-G2	0.32 lb
MK2000MP-G2	0.32 lb

Legend to Wiring Diagram

- L1, L2: To secondary of Isolation Transformer. Recommended 1.0A in-line fuses
- 12V DC Com.: Common connection of external Remote Indicator
- Safe: "Safe" light connection of external Remote Indicator
- Hazard: "Hazard" light connection of external Remote Indicator
- M-, M+: External mA meter (400 µA)
- RI1: Test button remote
- RI2: Local and system muting from LIM and Remote Indicator
- K1/NC: NC contact of the alarm relay K1
- K1/Common: Common contact of the alarm relay K1
- K1/NO: NO contact of the alarm relay K1
- GND2, LIM GND: Ground connections, if one is interrupted LIM will alarm
- L3/Test: Remote "Test" function or connection L3 in three phase systems

Safety Instructions



Electrical equipment shall only be installed by qualified personnel in consideration of the applicable safety regulations.

Standards

The BENDER Remote Indicator meets or exceeds all applicable U.S. and Canadian specifications. It complies with **NEC Article 517, NFPA 99, CEC, UL1022, CSA Z32.2** and is UL and CUL recognized.

Our Address BENDER MEDICAL PRODUCTS

700 Fox Chase
Coatesville, PA 19320
Phone: 800-356-4266
610-383-9200
Fax: 610-383-7100
E-mail: medical@bender.org

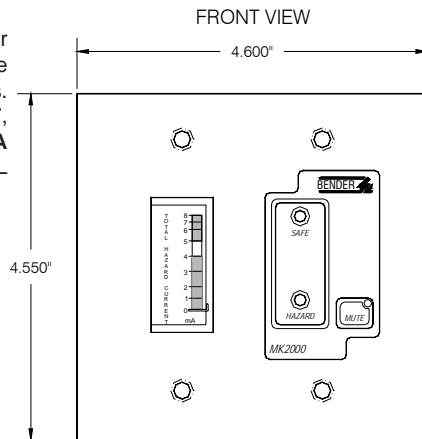

MK2000M-G2

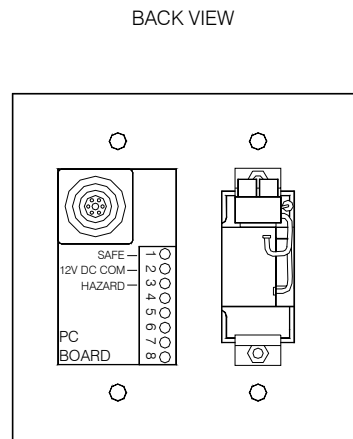

Dimension Diagram (inch)

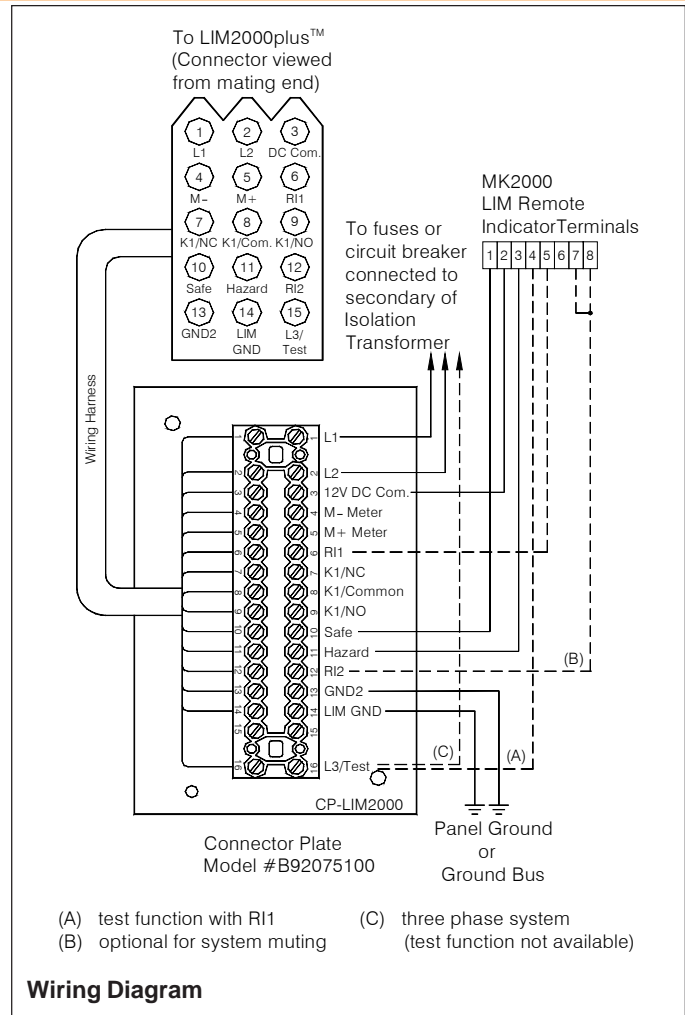
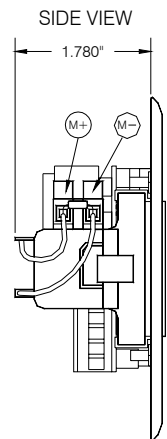

Wiring Diagram