

Line Isolation Monitor (LIM)

LIM2000plus[®]

for Single and Three Phase Systems

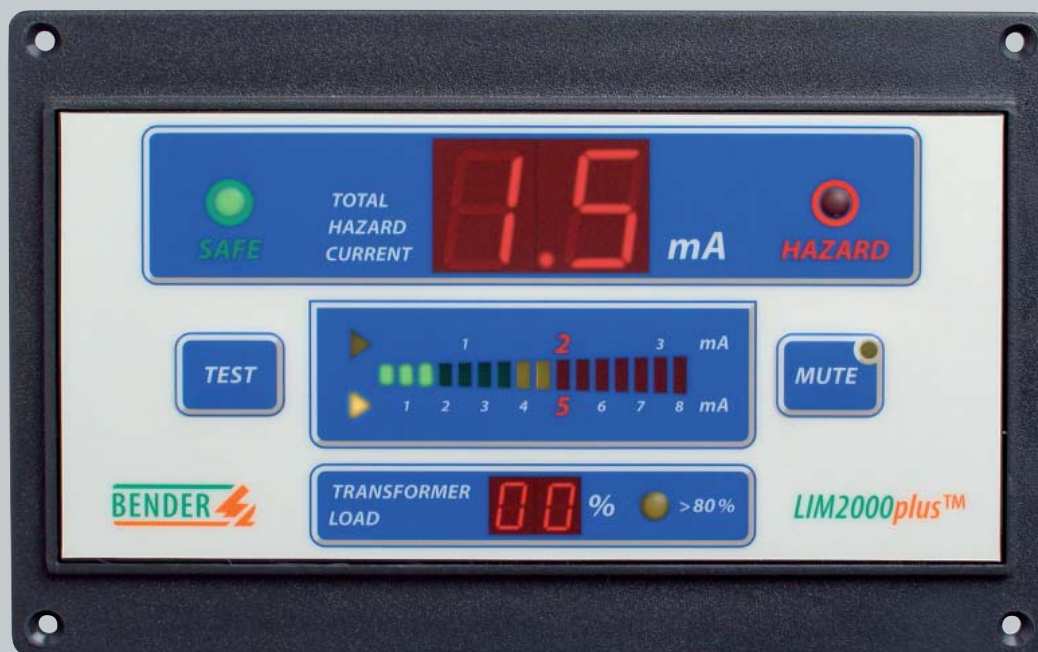

Line Isolation Monitor

LIM2000plus®



LIM2000plus®

Device features

- No interference with electrical equipment
- Special phase-locking circuitry for ultimate stability and repeatability
- Voltage-free SPDT contact for external alarm
- Provision for Remote Indicators
- Internal overload protection with automatic reset
- Easy to clean rugged Lexan front foil
- Digital & Analog Bar Graph Displays
- Automatic self-calibration and self-check
- Audible alarm volume adjustable via menu
- Transformer Load Monitoring
- RS-485 communication port

Product Description

The Line Isolation Monitor (LIM) measures the total leakage impedance to ground in an isolated (ungrounded) AC power system. Based on this information, the maximum Total Hazard Current (THC) is determined and displayed on a seven-segment display and LED bar graph display.

The LIM is available for operation in 50 or 60 Hz systems with AC voltages from 100 to 240 V. The supply voltage for the LIM is taken from the system being monitored.

For additional safety, two separate ground connections are provided. Each ground must be wired individually to the Reference Grounding Bus. A break in either connection will cause the LIM to alarm.

Monitoring the transformer load current is a desirable feature in modern operating room (OR) and intensive care units as more and more medical electrical (ME) equipment is being supplied with isolated power. A flashing yellow indicator LED warns the staff when the transformer has reached 80% capacity. At 100 % transformer capacity the indicator LED is solidly on and an audible alarm sounds as well.

The LIM2000plus® is ideal for retrofit applications regardless of the make or type of the existing product. No metal needs to be cut and simple instructions will generally facilitate a changeover in less than one hour.

Operational Information

Usually, the impedance between each isolated conductor and ground is different, resulting in a different current flowing through a person making physical contact between any one of the isolated conductors and ground. The LIM calculates and displays the true maximum value of the Total Hazard Current (THC). The BENDER LIM performs this function using a patented measurement technique.

The THC is shown on the seven-segment display and the LED bar graph. Normally, the green "SAFE" LED is illuminated, the display shows a low leakage value and the bar graph is in the non-alarm, or safe, green zone. THC levels will increase as additional loads are connected to the system and/or when a line-to-ground fault has suddenly occurred or is slowly developing. A visual and audible alarm is generated when the THC exceeds the LIM setting of either 2 mA or 5 mA. Relay output contacts are available, which can be wired into a circuit to trigger an external alarm.

The red "HAZARD" LED remains illuminated for the duration of the fault. The audible alarm can, however, be silenced by pushing the "MUTE" button at the discretion of personnel near the LIM. When the "MUTE" button is activated, the built-in amber LED in the "MUTE" button is illuminated to indicate a muted condition. After the fault is removed, the LIM will automatically reset to safe condition indications.

Activate the test button to check the LIM operation. Making this test does not add to the hazard current of a system in actual use, nor does the test include the effect of the line-to-ground stray impedance of the system.

The LIM has provisions to connect one or more remote indicators, with or without digital meter. The remote indicators duplicates the audible and visible alarm signals of the LIM.

The audible alarm volume level is adjustable via the configuration menu.

Standards

The BENDER LIM2000plus® Series LIM complies with UL 1022 in the U.S. and CSA-C22.2 No. 204-M1984 in Canada. The intent is to include the LIM as part of an isolated power system that conforms with the applicable requirements of ANSI/NFPA 99 and ANSI/NFPA 70 in the U.S. and in accordance with CAN/CSA-C22.2 No. 29-M1989 in Canada.

Safety Instructions



Only qualified personnel, in consideration of the applicable safety regulations, shall install electrical equipment!

Display LIM2000plus®

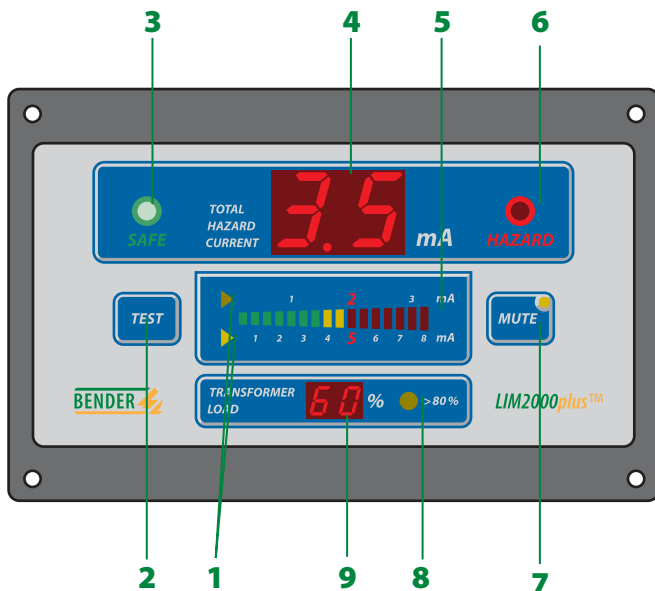

- 1 - THC Set Point LED Markers (amber) – Either 5 mA (U.S.) or 2 mA (Canada)
- 2 - “TEST” Button – Checks functions of the LIM
- 3 - “SAFE” LED (green) – Lit unless LIM is in alarm mode
- 4 - Digital Display – Displays THC in mA
- 5 - Analog LED Bar Graph – Displays THC in mA
- 6 - “HAZARD” LED (red) – Dark unless THC > Set Point
- 7 - “MUTE” Button w/built-in LED (amber) – Silences alarm buzzer
- 8 - “> 80%” LED (amber) – Flashes at 80%, solid on at 100% transformer load
- 9 - Digital Display “%” – Indicates % of rated transformer load

Error Code Listing

- ER 1.0 LIM-GND or GND2 connection interrupted
- ER 2.0 A/D converter calibration failed; hardware malfunction
- ER 3.0 Measuring circuit test failure; hardware malfunction
- ER 4.0 Actual system voltage is above LIM calibrated voltage
- ER 4.5 Actual signal voltage is above LIM calibrated voltage
- ER 5.0 LIM hardware malfunction
- ER 6.0 Program sequence interrupted; EMI interference
- ER 6.5 Program sequence interrupted; stack point indication too high
- ER ER Error in the current measuring circuitry

The error code is displayed on the seven-segment digital display (4). The display alternates between “ER” and the applicable numeric code, i.e. “ER” and “4.5”. The only exception is when the error code is “ER”. In this case, “ER” appears continuously in the display.

Ordering Details

LIM			
Product Type	Description	Approval	Article No.
LIM2000-1CB	100 – 120 V / 1-Phase		92075002
LIM2000-1CB	200 – 240 V / 1-Phase		92075004
LIM2000-3CB	200 – 240 V / 3-Phase		92075005

Remote Indicator			
Product Type	Description	Approval	Article No.
MK2000-G1	Mute		923520
MK2000-G2	Mute		923521
MK2000P-G1	Mute + Test		923523
MK2000C-G1	Mute + Overload		923522
MK2000M-G2	Mute + Overload	--	923540
MK2000CP-G1	Mute + Test + Overload		923529
MK2000CBM-G2	Mute + Test + Digital Metering + Overload	--	923545

Connector Plate			
Product Type	Description	Approval	Article No.
CP-LIM2000	LIM and remote connections		92075100
CP-LIM2000CB	LIM, CT, and digital remote		92075007

Current Transformer (CT)			
Product Type	Description	Approval	Article No.
STW3	Up to 100 A load current		98021000
STW4	Over 100 A load current		98021001

Standard Connector Plate Wiring Diagram

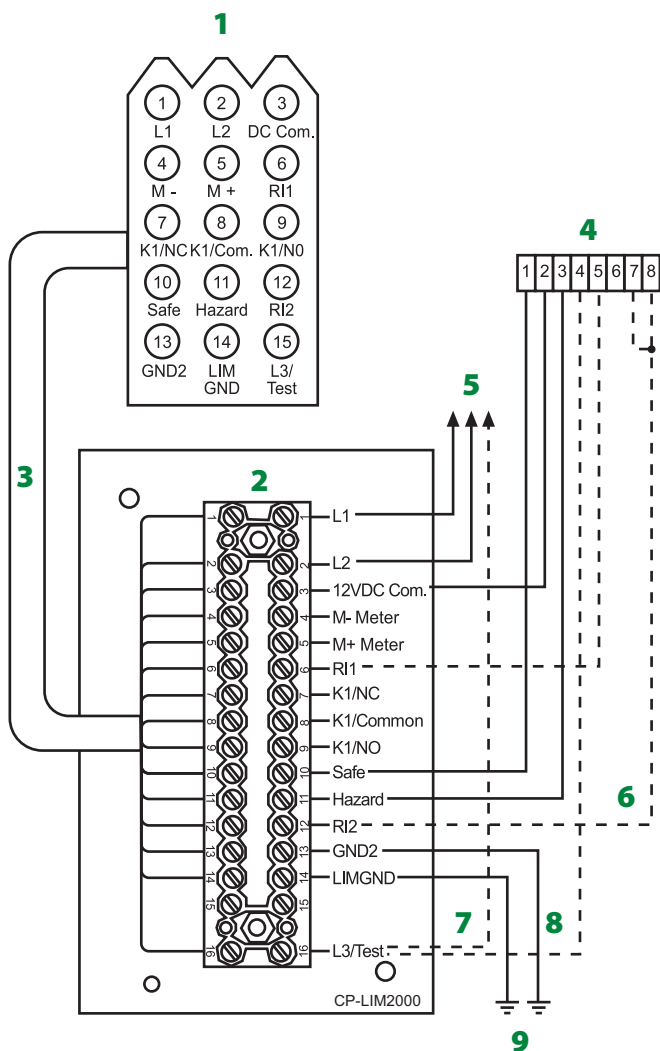

- 1 - To LIM2000plus™ (Connector viewed from mating end)
- L1, L2 To secondary of Isolation Transformer.
- 12 V DC Com. Common connection
- M-, M+ External mA meter (400 µA)
- RI1 Test button source
- K1/NC NC contact of the alarm relay K1
- K1/Common Common contact of the alarm relay K1
- K1/NO NO contact of the alarm relay K1
- Safe "Safe" light connection of external Remote Indicator
- Hazard "Hazard" light connection of external Remote Indicator
- RI2 Local and system muting from LIM and Remote Indicator
- GND2, LIM GND Ground connections, if one is interrupted LIM will alarm
- L3/Test Remote "Test" function or connection L3 in three phase systems
- 2 - Connector Plate CP-LIM2000
- 3 - Wiring Harness
- 4 - MK2000 LIM Remote Indicator Terminals
- 5 - To fuses or circuit breaker connected to secondary of Isolation Transformer
- 6 - optional for system muting
- 7 - three phase system (test function not available)
- 8 - test function with RI1
- 9 - Panel Ground or Ground Bus

Load Monitoring & RS-485 Connector Plate

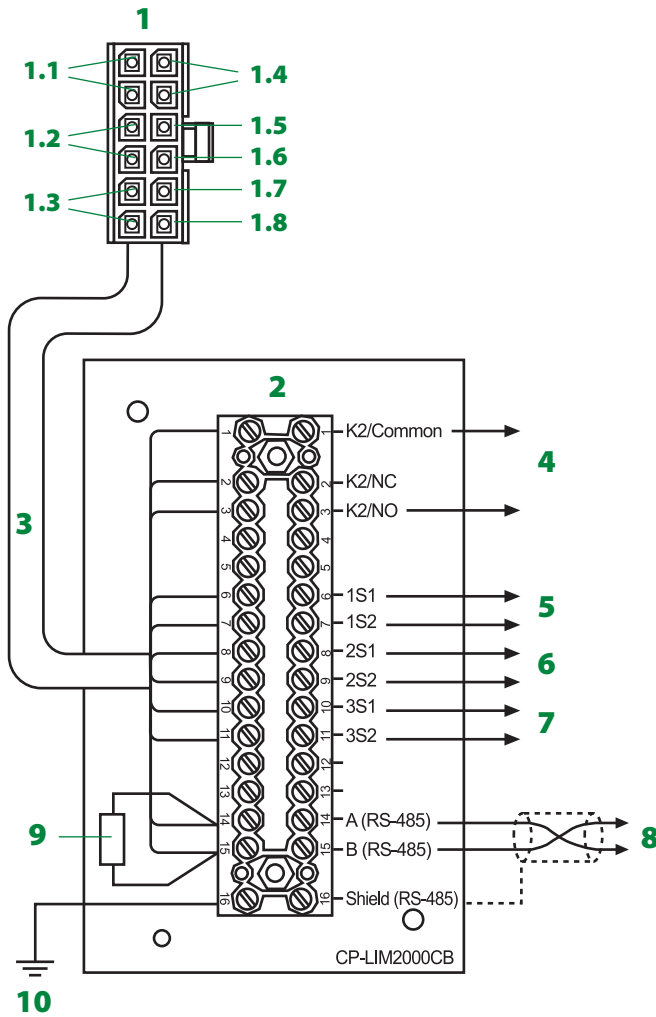

- 1 - To LIM 2000plus™ (Connector viewed from mating end)
 - 1.1 - 1S1, 1S2 To Current Transformer (CT) Connections (1Phase)
 - 1.2 - 2S1, 2S2 To Current Transformer (CT) Connections (3Phase)
 - 1.3 - 3S1, 3S2 To Current Transformer (CT) Connections (3Phase)
 - 1.4 - A, B Shield RS-485 Communication
 - 1.5 - No Connection
 - 1.6 - K2/Common Overload Indicator on MK2000CBM-G2
 - 1.7 - K2/NC NC contact of the alarm relay K2
 - 1.8 - K2/NO Overload Indicator on MK2000CBM-G2
- 2 - Load Connector Plate CP-LIM2000CB
- 3 - Wiring Harness
- 4 - To MK2000CBM Remote Indicator (Overload Indicator)
- 5 - To Load Monitoring CT (Current Transformer) for L1
- 6 - To Load Monitoring CT (Current Transformer) for L2
- 7 - To Load Monitoring CT (Current Transformer) for L3
- 8 - Shielded, Twisted Pair Cable for RS-485 Communication to MK2000CBM Remote Indicator (If required)
- 9 - 120 ohm, ¼ Watt Termination Resistor (Resistor also required at MK2000CBM Remote Indicator)
- 10 - Panel Ground or Ground Bus

Wiring Diagram

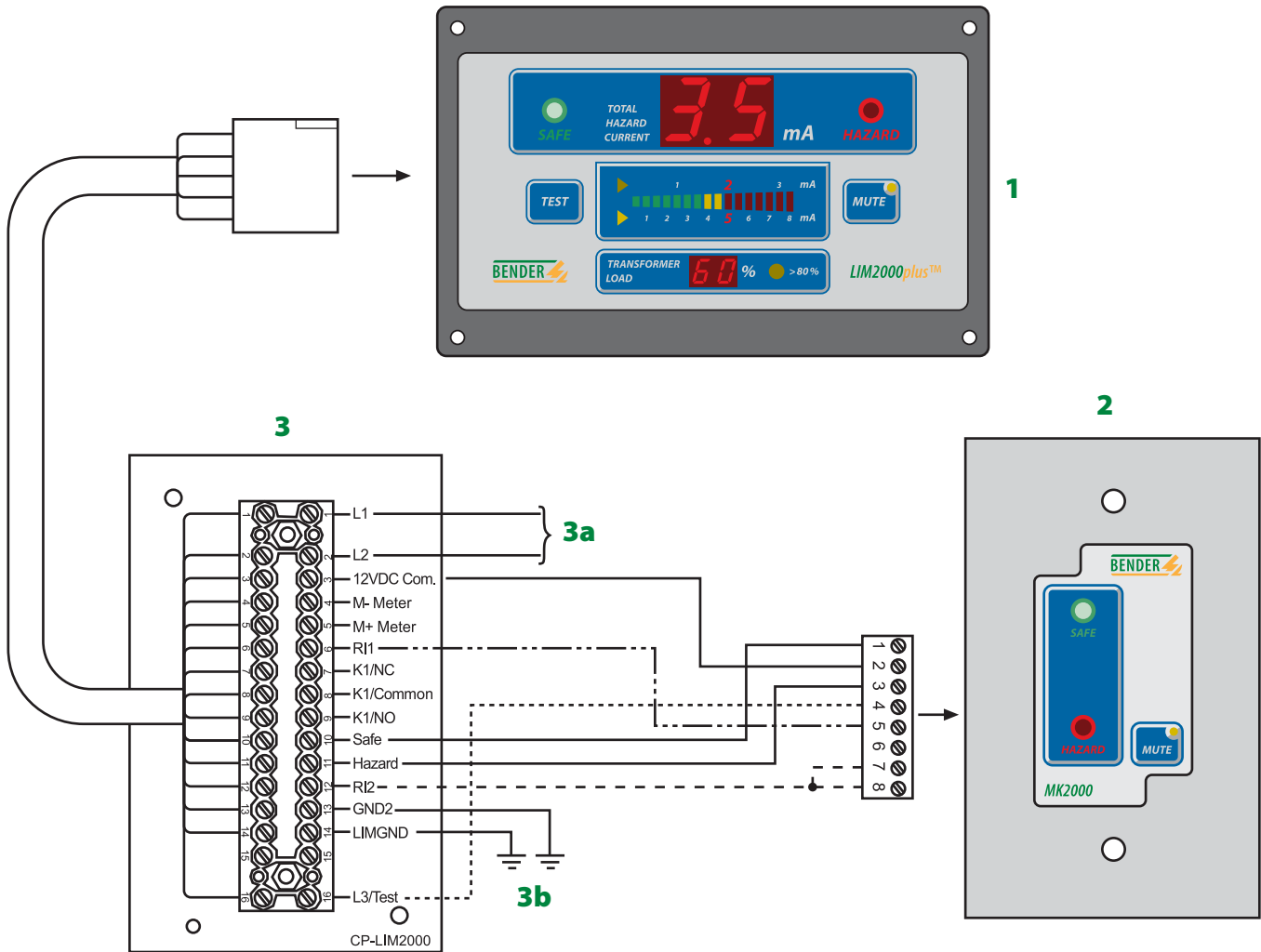

1 - LIM2000plus™

2 - MK2000-G1

3 - Connector Plate CP-LIM2000

3a - AC Power Circuit According to LIM rating

3b - Panel Ground or Ground Bus

————— Connections required in Single Phase systems using MK2000-G1 Remote Indicator

----- Additional connection required in Single Phase systems using MK2000P-G1 Remote indicator w/TEST Button. NOTE: "TEST" function from Remote Indicator is not available for 3 Phase systems. L3/TEST connection is used as L3 in 3 Phase systems.

..... Additional connections required for "System Muting" option.

Wiring Diagram

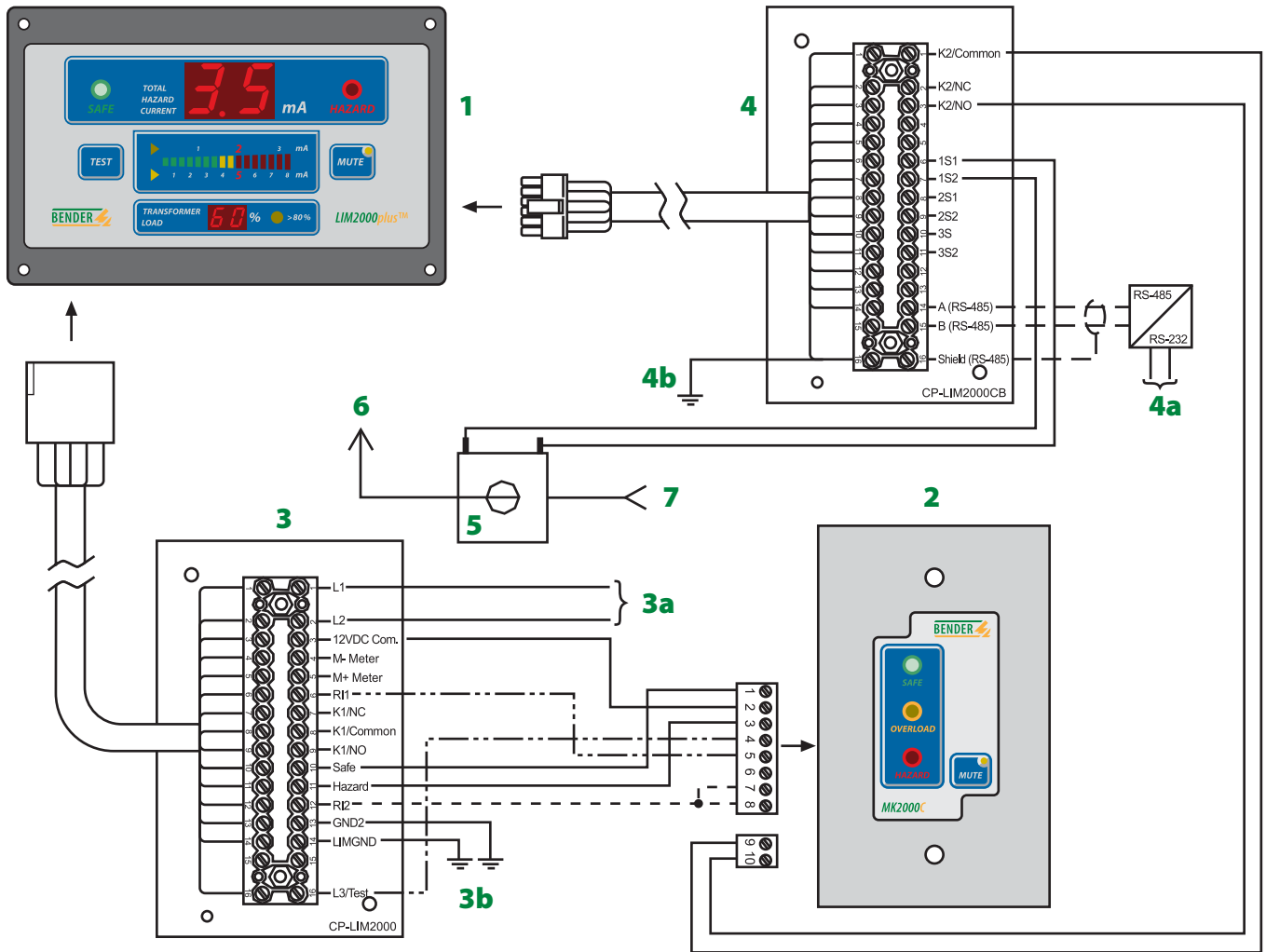

- 1 - LIM2000plus™
 - 2 - MK2000C-G1
 - 3 - Connector Plate CP-LIM2000
 - 3a - AC Power Circuit According to LIM rating
 - 3b - Panel Ground or Ground Bus
 - 4 - Connector Plate CP-LIM2000CB
 - 4a - To MK2000C
 - 4b - Panel Ground or Ground Bus
 - 5 - Current Transformer
 - 6 - L1 to Load Center/Branch Circuit Breakers
 - 7 - L1 from transformer secondary
-
- Connections required in Single Phase systems using MK2000C-G1 Remote Indicator
 - - - - Additional connection required in Single Phase systems using MK2000P-G1 Remote indicator w/TEST Button. NOTE: "TEST" function from Remote Indicator is not available for 3 Phase systems. L3/TEST connection is used as L3 in 3 Phase systems. Overload option requires three (3) Current Transformers, (L1, L2 & L3), in 3 Phase systems.
 - - - - Additional connections required for "System Muting" option.
 - - - - Connections required for "RS-485 Interface".

Wiring Diagram

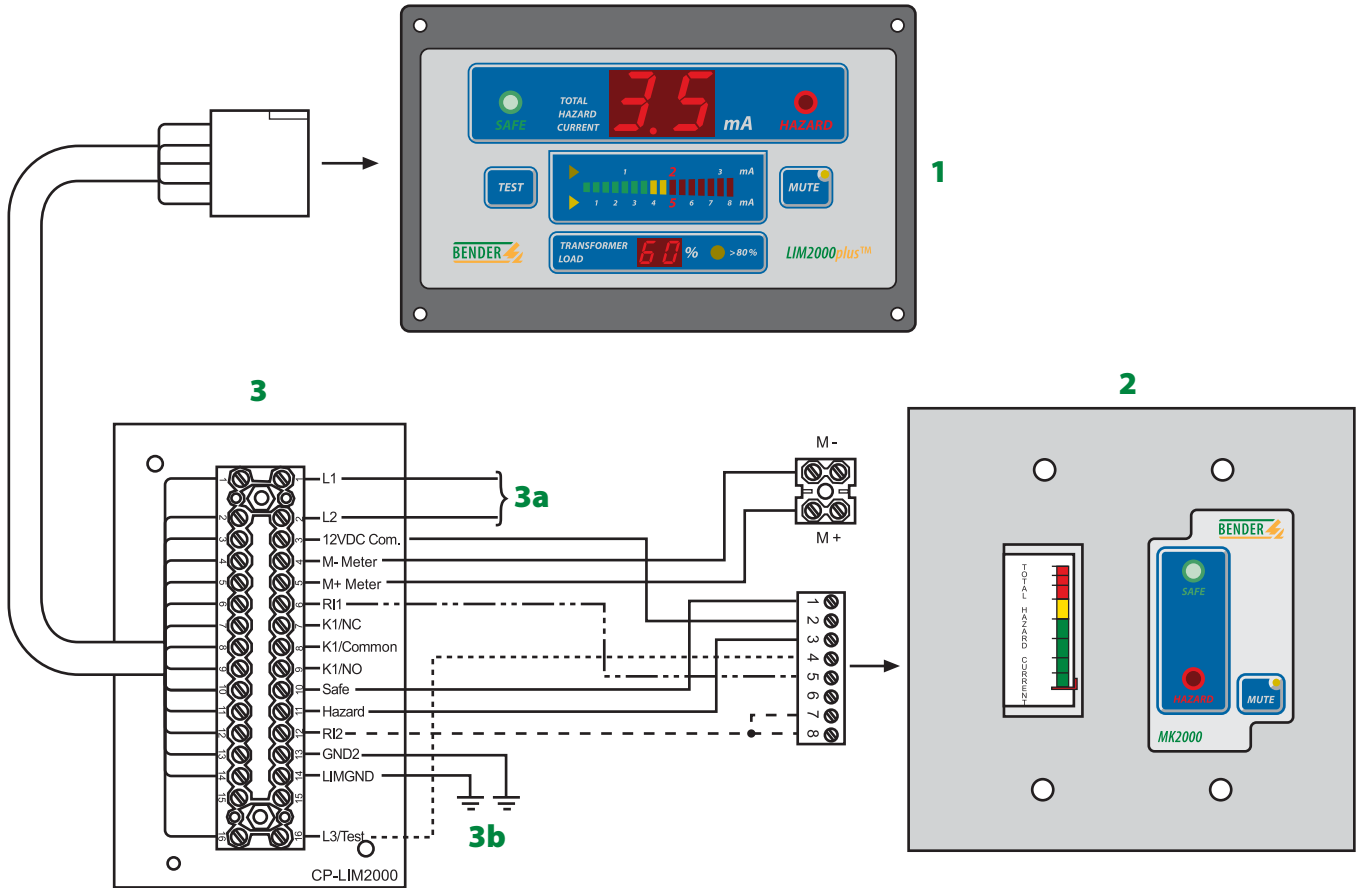

1 - LIM2000plus™

2 - MK2000M-G2

3 - Connector Plate CP-LIM2000

3a - AC Power Circuit According to LIM rating

3b - Panel Ground or Ground Bus

————— Connections required in Single Phase systems using MK2000M-G2 Remote Indicator

- - - - - Additional connection required in Single Phase systems using MK2000P-G1 Remote indicator w/TEST Button. NOTE: "TEST" function from Remote Indicator is not available for 3 Phase systems. L3/TEST connection is used as L3 in 3 Phase systems.

- - - - - Additional connections required for "System Muting" option.

Wiring Diagram

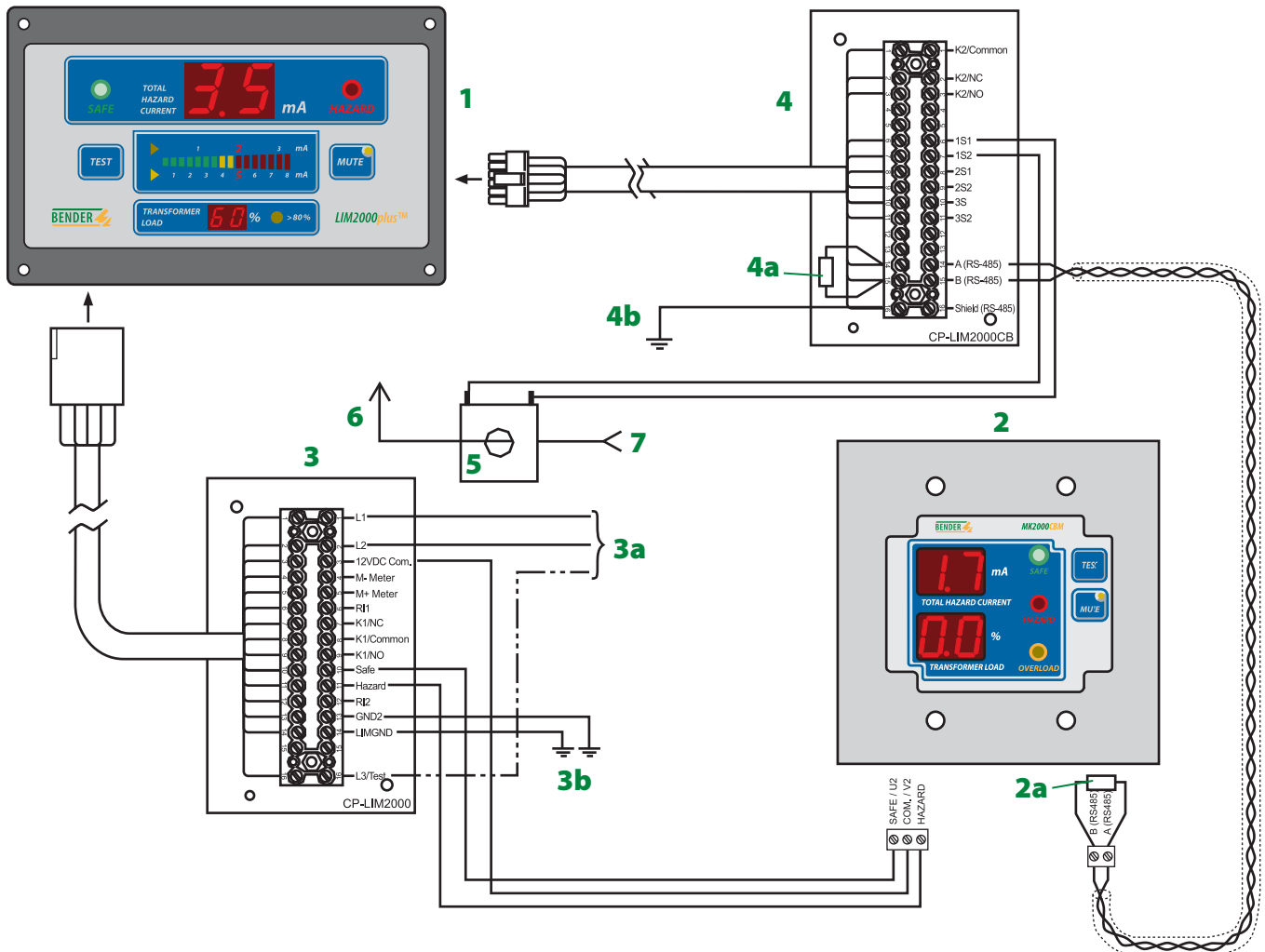

- 1 - LIM2000plus™
 - 2 - MK2000CBM-G2
 - 2a - Termination Resistor
 - 3 - Connector Plate CP-LIM2000
 - 3a - AC Power Circuit According to LIM rating
 - 3b - Panel Ground or Ground Bus
 - 4 - Connector Plate CP-LIM2000CB
 - 4a - Termination Resistor
 - 4b - Panel Ground or Ground Bus
 - 5 - Current Transformer
 - 6 - L1 to Load Center/Branch Circuit Breakers
 - 7 - L1 from transformer secondary
- Connections required in Single Phase systems using MK2000CBM-G2 Remote Indicator
 - - - - L3/Test connection is used as L3 in 3 Phase systems. Overload option requires three (3) Current Transformers, (L1, L2 & L3), in 3 Phase systems.
 - - - - Shielded, twisted pair wire required for RS485 connection. **Ground shield at one end only as shown.** Termination Resistor – 120 ohm, 1/4 watt.

Technical Data

LIM2000plus® Technical Specification

Insulation Class in acc. to UL1022	
Dielectric Voltage-withstand Test	1850 V (1 second)
Rated Service Rating	continuous operation
Rated Mains Voltage of VN	100...120 V AC or 200...240 V AC 1ph. 200...240 V AC 3ph.
Frequency Range of VN	50...60 Hz (+/- 5 %)
Operating Range of VN	85...110 % of rated voltage
Max. Power Consumption	22 VA
Max. Measuring Current	20 µA
Monitor Hazard Current	
100...120 V / 200...240 V	max. 46 / 78 µA
Min. Internal Impedance at 1Ph / 3Ph (60 Hz)	3.5 / 3.2 Meg Ω
Nominal Response Value	5 mA changeable to 2 mA
Response Tolerance	1.8 to 2 mA or 4.5 to 5 mA
Response Time	< 4 sec.
Response Hysteresis	20% of response value
Contacts	one voltage-free SPDT contact one voltage-free SPDT contact for load monitoring
Outputs	12 V DC, 200 mA max. remote indicator output, analog and digital display output
Rated Contact Voltage	250 V/24 V DC
Make Capacity	4 A AC/ 4 A DC
Break capacity at 24 V DC and L/R = 0	4 A
Switching Life (240 V AC / 60 Hz)	2 x 10 ⁵ cycles
Operation Mode	continuous
LIM Overload Protection	built-in thermal overload with automatic reset
Operating Temperature Range	+32...+126 °F 0...+50 °C
Storage Temperature	-13...+158 °F -25...+70 °C
Mounting Orientation	any
Connector	15 pin Molex, type 03-09-2152 and 12 pin Molex
Communication Port	RS-485 Communication
Weight	approx. 1.2 lb (550 gr.)

Dimension Diagram LIM2000plus®

(Dimensions in inch)

Physical Details

The LIM is less than 2-1/2 "deep. Cut-out needed for new flush panel mounting is 7" -x 4-7/16" (+0,-1/32"). Cut-out needed for surface panel mounting is 5-3/8" -x 3-1/4" (+0,-1/32"). Mounting holes are on 4" and 6-1/2" centers. A 15-pin and a 12-pin female Molex connector are built into the back of the LIM2000plus®.

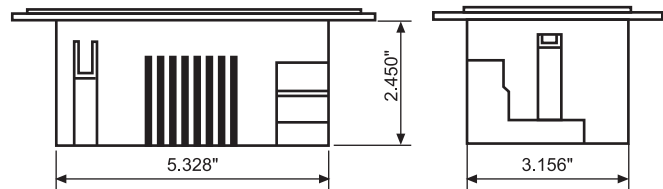
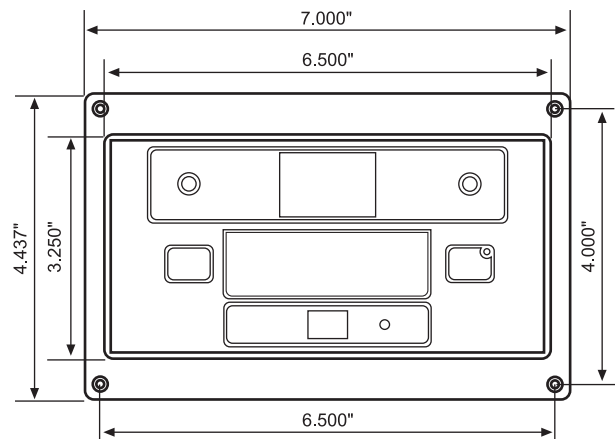

Technical Data Connector Plates
LIM2000plus® Connector Plate – CP-LIM2000

Cable Length	20"
Terminal Strip	16 terminals
Connector	15 pin Molex
Conductor Size	22...12 AWG
Tightening torque	8 lb In.
Mounting Orientation	as disired
Weight	Approx. 7 oz.

LIM2000plus® Auxiliary Connector Plate – CP-LIM2000CB

Cable Length	20"
Terminal Strip	16 terminals
Connector	12 pin Molex
Conductor Size	22...12 AWG
Tightening torque	8 lb In.
Mounting Orientation	as desired
Weight	Approx. 7 oz.

Technical Data for MK2000-G1 / MK2000-G2 / MK2000P-G1 / MK2000C-G1 / MK2000M-G2 / MK2000CP-G1 / MK2000CBM-G2

Operating voltage	12V DC or 12V AC
Max. current	50 mA
(MK2000CBM-G2)	100 mA)
Operation class	continuous operation
Ambient temperature	
when operating	+32° F to +122° F 0° C to +50°
when stored	-13° F to +158° F -25° C to +70° C
Connection	screw terminal block
Conductor size	30...12 AWG
Tightening torque	5...7 lb In.
Mounting	by screws
Weight	
MK2000-G1 / MK2000P-G1 / MK2000C-G1 / MK2000CP-G1	0.25 lb
MK2000-G2 / MK2000M-G2 / MK2000CBM-G2	0.32 lb

Dimension Diagram Load Monitoring Current Transformer (CT)

(Dimensions in inch)

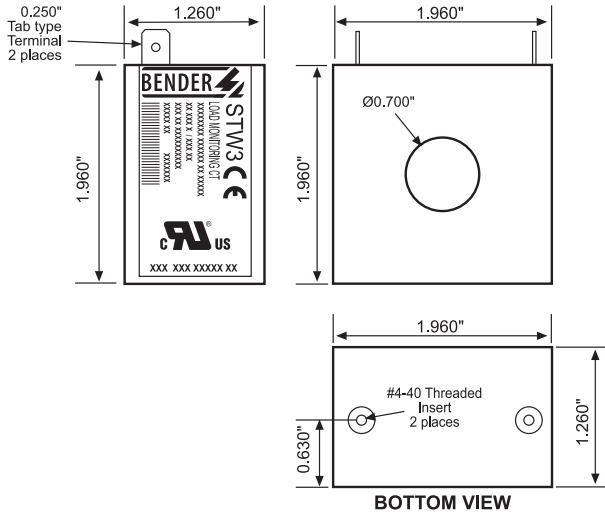

Dimension Diagram

MK2000-G1 / MK2000P-G1 / MK2000C-G1 / MK2000CP-G1

(Dimensions in inch)

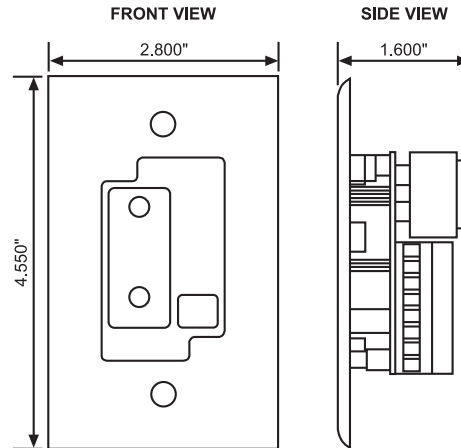

Dimension Diagram MK2000M-G2

(Dimensions in inch)

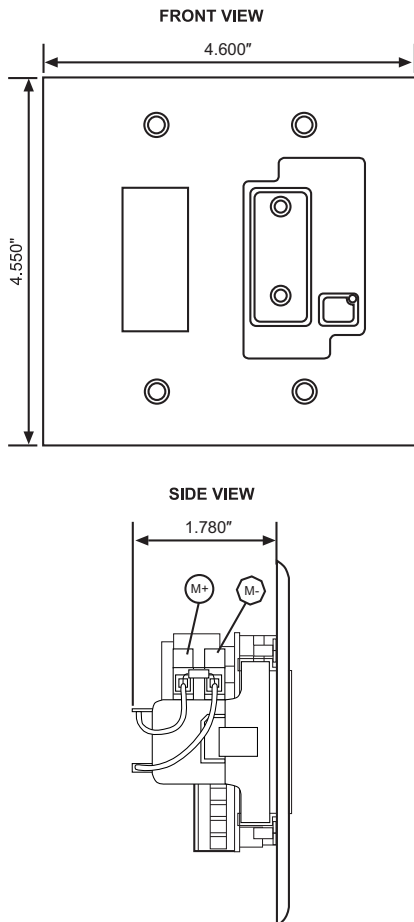

Dimension Diagram MK2000CBM-G2

(Dimensions in inch)

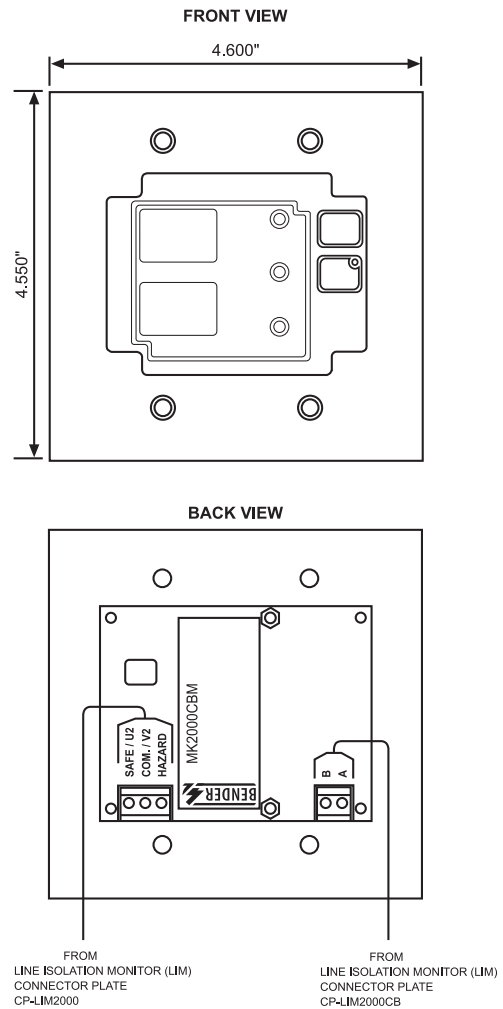

Remote Indicators





Dipl.-Ing. W. Bender GmbH & Co. KG

P.O. Box 1161 • 35301 Grünberg • Germany

Londorfer Straße 65 • 35305 Grünberg • Germany

Tel.: +49 6401 807-0 • Fax: +49 6401 807-259

E-Mail: info@bender-de.com • www.bender-de.com

Power in electrical safety