

VME421H

Multi-functional monitoring relay for undervoltage, overvoltage and frequency monitoring in AC/DC systems without external supply voltage



VME421H

Device features

- Undervoltage, overvoltage and frequency monitoring of AC/DC systems
9.6...150 V (VME421H-D-1)
70...300 V (VME421H-D-2)
- Without external supply voltage
- Integrated energy backup
- Different monitoring functions selectable
< U, > U or < U/> U, < f, > f or < f / > f
- Start-up delay, response delay, delay on release
- Adjustable switching hysteresis
- r.m.s. value measurement (AC + DC)
- Digital measured value display via multi-functional LC display
- Preset function (automatic assignment of basic parameters)
- LEDs: Power On, Alarm 1, Alarm 2
- Measured value memory for operating value
- Continuous self monitoring
- Internal test/reset button
- Two separate alarm relays (gold-plated relay contacts), one changeover contact each
- N/C or N/O operation and fault memory behaviour selectable
- Password protection for device setting
- Sealable transparent cover
- Two-module enclosure (36 mm)
- Indication of the system frequency
- RoHS-compliant

Approvals



Product description

The voltage relays of the VME421H series are designed to monitor the frequency, undervoltage, overvoltage and the voltage between two threshold values (window discriminator function) in AC and DC systems. The voltages are measured as r.m.s. values. The currently measured value is continuously shown on the LC display. The measured value leading to the activation of the alarm relays will be stored. Due to adjustable response times, installation-specific characteristics, such as device-specific start-up procedures, short-time voltage fluctuations, etc. can be considered. Device version VME421H takes the supply voltage from the system being monitored and utilizes an internal energy backup.

Typical applications

- Single-phase voltage and frequency monitoring of machines and electrical installations
- Earth fault monitoring in medium-voltage systems via voltage transformers
- Monitoring of battery systems
- Switching on and switching off at a certain voltage level

Function

Once the supply voltage is applied, the start-up delay "t" is activated. Measured voltage and frequency values changing during this time do not influence the switching state of the alarm relays.

The devices provide two separately adjustable measuring channels (overvoltage/undervoltage). When the measuring quantity exceeds the response value (Alarm 1) or falls below the response value (Alarm 2), the time of the response delays "t_{on1/2}" begins. Once the response delay has elapsed, the alarm relays switch and the alarm LEDs light. When the measuring value exceeds or falls below the release value (response value plus hysteresis) after the alarm relays have switched, the selected release delay "t_{off}" begins. When "t_{off}" has elapsed, the alarm relays switch back to their initial position. When the fault memory is activated, the alarm relays remain in alarm state until the reset button R is pressed.

Energy backup

Also in the event of complete power failure of the system being monitored, the delay times are effective during the energy backup time. If the fault memory is set to continuous mode, the alarm parameters remain stored, even on failure of the supply voltage.

Preset function

After connecting the device for the first time, the nominal system voltage will be determined (PrE run), and the response values for overvoltage and undervoltage as well as for underfrequency and overfrequency will automatically be set. When no voltage is determined within a system voltage range (PrE run), the response values will be set to the minimum or maximum voltage. In this case, the message "AL not SET" appears on the display. As long as no key is pressed, a nominal system voltage is being searched cyclically (PrE run). If a key is pressed, the search will be interrupted and the message "AL not SET" disappears. In this case, the appropriate response values have to be set in the menu. When activating the frequency monitoring function, the preset frequency will automatically be applied.



Operating elements

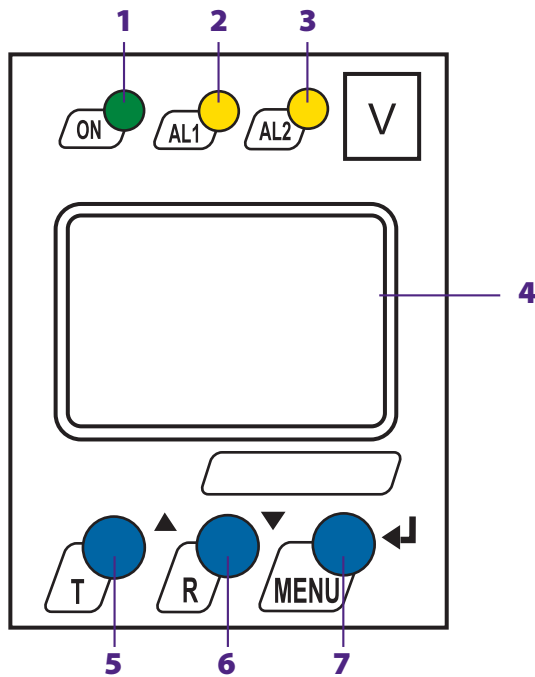

- 1 - LED Power On "ON" (green); lights when supply voltage is applied and flashes in the event of system fault alarm.
- 2 - Alarm LED "AL1" (yellow), lights when the set response value $> U / < f / > f$ is exceeded and flashes in the event of system fault alarm.
- 3 - Alarm LED "AL2" (yellow), lights when the value falls below the set response value $< U / < f / > f$ and flashes in the event of system fault alarm.
- 4 - Multi-functional LC display.
- 5 - Test button "T": UP key: To change the measured value display, move downwards in the menu or change parameters.
To call up the self test: Press the key > 1.5 s
- 6 - Reset button "R": DOWN key: To change the measured value display, move downwards in the menu or change parameters.
To delete stored insulation fault alarms: Press the key > 1.5 s
- 7 - MENU key: Enter key: To confirm the measured value display or change parameters.
To call up the menu system: Press the key > 1.5 s
Press ESC key > 1.5 s: To abort an action or to return to the previous menu level.

Wiring diagram

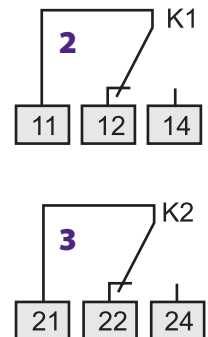
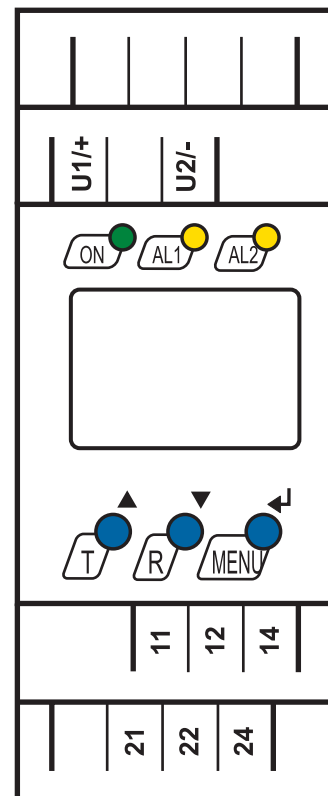
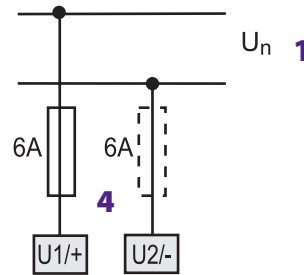

- 1 - Connection to the system/load being monitored
- 2 - Alarm relay K1: Configurable $f < U / > U / < f / > f / \text{ERROR}$
- 3 - Alarm relay K2: Configurable $f < U / > U / < f / > f / \text{ERROR}$
- 4 - Line protection according to IEC 60364-4-43
A 6 A fuse is recommended. If being supplied from an IT system, both lines have to be protected by a fuse.

Ordering information

Type	Supply voltage U_s	Nominal system voltage U_n^*	Display range	Response value	Art. No.
VME421H-D-1	--	DC 9.6...150 V / AC 15...460 Hz 9.6...150 V	AC / DC 9.6...150 V	AC / DC 9.6...150 V	B 9301 0003
VME421H-D-2	--	DC 70...300 V / AC 15...460 Hz 70...300 V	AC / DC 70...300 V	AC / DC 70...300 V	B 9301 0004

* Absolute values

Accessories

Type	Art No.
Mounting clip for screw fixing (1 piece per device)	B 9806 0008

Timing diagram voltage monitoring

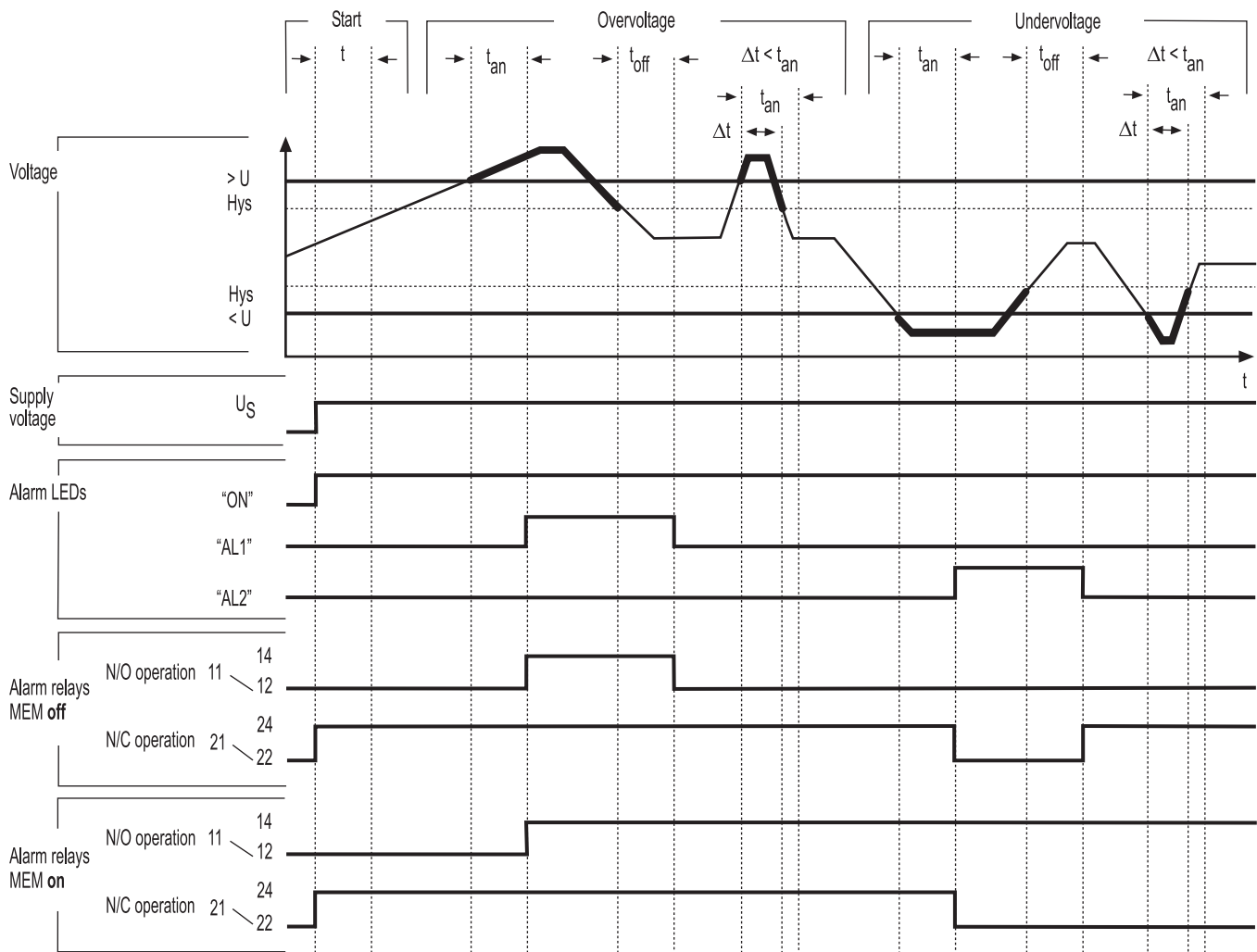

t - Start-up delay

t_{an} - Response time

t_{off} - Delay on release

Dimension diagram XM421 Dimensions in mm

Open the front plate cover in direction of arrow!

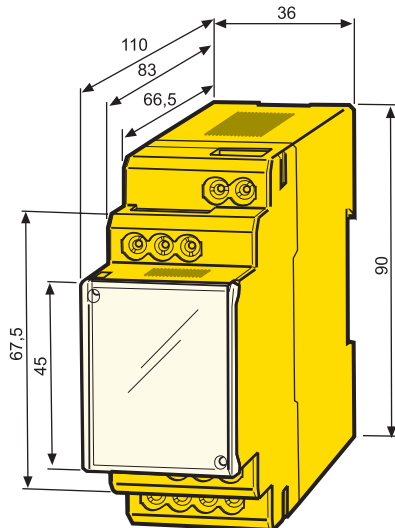

Screw fixing

Note: The upper mounting clip must be ordered separately (see ordering information).

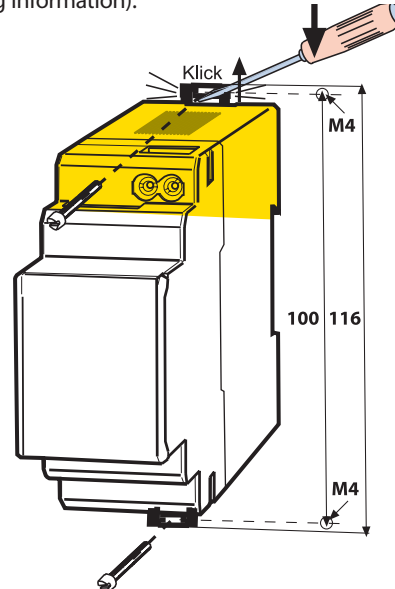

Technical data monitoring relay for undervoltage, overvoltage and frequency monitoring VME421H
Insulation coordination acc. to IEC 60664-1 / IEC 60664-3

Rated insulation voltage	250 V
Rated impulse voltage/pollution degree	2.5 kV / III
Protective separation (reinforced insulation) between: (U1/+, U2/-) - (11-12-14) - (21-22-24)	
Voltage test acc. to IEC 61010-1	2.21 kV

Supply voltage

VME421H-D-1:	
Supply voltage U_s	none (internally supplied by U_n)
VME421H-D-2:	
Supply voltage U_s	none (internally supplied by U_n)
Power consumption	≤ 4 VA

Measuring circuit

Measuring range (r.m.s. value) (VME421H-D-1)	AC / DC 0...150 V
Measuring range (r.m.s. value) (VME421H-D-2)	AC / DC 0...300 V
Rated frequency f_n	DC, 15...460 Hz
Frequency display range	10...500 Hz

Response values

VME421H-D-1:	
Undervoltage $< U$ (Alarm 2)	AC / DC 9.6...150 V
Overvoltage $> U$ (Alarm 1)	AC / DC 9.6...150 V
Preset function:	
Undervoltage $< U$ ($0.85 U_n$)* für $U_n = 120$ V / 60 V / 24 V	102 V / 51 V / 20.4 V
Overvoltage $> U$ ($1.1 U_n$)* für $U_n = 120$ V / 60 V / 24 V	132 V / 66 V / 26.4 V
Resolution of setting U 9.6...49.9 V	0.1 V
Resolution of setting U 50...150 V	1 V

VME421H-D-2:	
Undervoltage $< U$ (ALARM 2)	AC / DC 70...300 V
Overvoltage $> U$ (ALARM 1)	AC / DC 70...300 V
Resolution of setting U 70...300 V	1 V

Preset function:	
Undervoltage $< U$ ($0.85 U_n$)* für $U_n = 230$ V / 120 V	196 V / 102 V
Overvoltage $> U$ ($1.1 U_n$)* für $U_n = 230$ V / 120 V	253 V / 132 V

VME421H...:	
Relative percentage error voltage at 50/60 Hz	± 1.5 %, ± 2 digits
Relative percentage error in the voltage range 15...460 Hz	± 3 %, ± 2 digits
Hysteresis U	1...40 % (5 %)*
Underfrequency $< Hz$	10...500 Hz
Overfrequency $> Hz$	10...500 Hz
Resolution of setting f 10.0...99.9 Hz	0.1 Hz
Resolution of setting f 100...500 Hz	1 Hz

Preset function:	
Underfrequency for $f_n = 16.7$ Hz / 50 Hz / 60 Hz / 400 Hz	16.2 Hz / 49.5 Hz / 59.5 Hz / 399 Hz
Overfrequency for $f_n = 16.7$ Hz / 50 Hz / 60 Hz / 400 Hz	17.2 Hz / 50.5 Hz / 60.5 Hz / 401 Hz
Hysteresis frequency H_{ys} Hz	0.2...2 Hz (0.2 Hz)*
Relative percentage error in the frequency range 15...460 Hz	± 0.2 %, ± 1 digits

Specified time

Start-up delay t	0...99 s (0 s)*
Response delay $t_{on1/2}$	0...99 s (0 s)*
Delay on release t_{off}	0...99 s (0.5 s)*
Operating time voltage t_{ae}	DC/AC 16.7 Hz: ≤ 130 ms, AC 42...460 Hz: ≤ 70 ms
Operating time frequency t_{ae}	AC 15...460 Hz: ≤ 310 ms
Response time t_{an}	$t_{an} = t_{ae} + t_{on1/2}$
Discharging time energy backup on power failure (VME421H-D-1)	3 s
Discharging time energy backup on power failure (VME421H-D-1)	≥ 2.5 s at $f_n < 42$ Hz
Discharging time energy backup on power failure (VME421H-D-2)	≥ 4 s at DC 70 V
	≥ 6 s at DC 80 V/AC 70 V
Charging time energy backup (VME421H-D-1)	≤ 60 s
Charging time energy backup (VME421H-D-2)	≤ 120 s
Recovery time t_b	≤ 300 ms

Displays, memory

Display	LC display, multi-functional, not illuminated
Display range measured value (VME421H-D-1)	AC/DC 0...150 V
Display range measured value (VME421H-D-2)	AC/DC 0...300 V
Operating error voltage at 50/60 Hz	± 1.5 %, ± 2 digits
Relative percentage error in the voltage range 15...460 Hz	± 3 %, ± 2 digits
Relative percentage error in the frequency range 15...460 Hz	± 0.2 %, ± 1 digits
History memory (HiS) for the first alarm value	data record measured values
Password	off / 0...999 (off)*
Fault memory (M) alarm relay	on / off / con (on)*

Switching elements

Number of changeover contacts	2 x 1 (K1, K2)
Operating principle	N/C or N/O operation
	K2: Err, $< U$, $> U$, $< Hz$, $> Hz$ (undervoltage $< U$: N/C operation n.c.)*
	K1: Err, $< U$, $> U$, $< Hz$, $> Hz$ (overvoltage $> U$: N/O operation n.o.)*
Electrical service life under rated operating conditions, number of cycles	10 000
Contact data acc. to IEC 60947-5-1:	
Utilization category	AC 13 AC 14 DC-12 DC-12 DC-12
Rated operational voltage	230 V 230 V 24 V 110 V 220 V
Rated operational current	5 A 3 A 1 A 0.2 A 0.1 A
Minimum contact load	1 mA at AC / DC 10 V

Environment / EMC

EMC	IEC 61326-1
Operating temperature	-25 °C...+55 °C
Classification of climatic conditions acc. to IEC 60721:	
Stationary use (IEC 60721-3-3)	3K5 (except condensation and formation of ice)
Transport (IEC 60721-3-2)	2K3 (except condensation and formation of ice)
Storage (IEC 60721-3-1)	1K4 (except condensation and formation of ice)
Classification of mechanical conditions acc. to IEC 60721:	
Stationary use (IEC 60721-3-3)	3M4
Transport (IEC 60721-3-2)	2M2
Storage (IEC 60721-3-1)	1M3

Connection

Connection	screw terminals
Connection properties:	
rigid / flexible / conductor sizes	0.2...4 / 0.2...2.5 mm ² / AWG 24...12
Multi-conductor connection (2 conductors with the same cross section):	
rigid/flexible	0.2...1.5 mm ² / 0.2...1.5 mm ²
Stripping length	8...9 mm
Tightening torque	0.5...0.6 Nm

Other

Operating mode	continuous operation
Mounting	any position
Degree of protection, internal components (IEC 60529)	IP30
Degree of protection, terminals (IEC 60529)	IP20
Enclosure material	polycarbonate
Flammability class	UL94 V-0
DIN rail mounting acc. to	IEC 60715
Screw fixing	2 x M4 with mounting clip
Product standard	IEC 61010-1 and according to IEC 60255-6
Operating manual	TGH1403
Weight	≤ 240 g

() * = factory setting