

VMD421H

Multi-functional voltage relays for frequency, overvoltage, undervoltage, phase sequence, phase failure and asymmetry monitoring in 3(N)AC systems – without external supply voltage

3.1



VMD421H

Device features

- Undervoltage, overvoltage and frequency monitoring in 3(N)AC systems 70...500/288 V
- Without external supply voltage
- Integrated energy backup
- Asymmetry, phase failure and phase sequence monitoring
- Different monitoring functions selectable $< U, > U$ or $< U/> U, < f, > f$ or $< f / > f$
- Start-up delay, response delay, delay on release
- Adjustable switching hysteresis
- r.m.s. value measurement (AC)
- Digital measured value display via multi-functional LC display
- Preset function (automatic assignment of basic parameters)
- LEDs: Power On, Alarm 1, Alarm 2
- Measured value memory for operating value
- Continuous self monitoring
- Internal test/rest button
- Two separate alarm relays (gold-plated relay contacts), one changeover contact each
- N/C or N/O operation and fault memory behaviour selectable
- Password protection for device setting
- Sealable transparent cover
- Two-module enclosure (36 mm)
- RoHS-compliant

Approvals



Product description

The multi-functional voltage relays of the VMD421H series are designed to monitor the frequency, undervoltage and overvoltage and the voltage between two threshold values (window discriminator function) in 3(N)AC systems. The voltages are measured as r.m.s. values. The currently measured value is continuously shown on the LC display. The measured value leading to the activation of the alarm relays will be stored. Due to adjustable response times, installation-specific characteristics, such as device-specific start-up procedures, short-time voltage fluctuations, etc. can be considered. Device version VMD421H takes the supply voltage from the system being monitored and utilizes an internal energy backup.

Typical applications

- Monitoring of voltage-sensitive machines and electrical installations
- Switching on and switching off at a certain voltage level
- Monitoring of stand-by and emergency supply systems
- Supply voltage monitoring of portable loads

Function

Once the supply voltage is applied, the start-up delay "t" is activated. Measured voltage and frequency values changing during this time do not influence the switching state of the alarm relays.

The devices provide two separately adjustable measuring channels (overvoltage/undervoltage). When the measuring quantity exceeds the response value (Alarm 1) or falls below the response value (Alarm 2), the time of the response delays "t_{on 1/2}" begins. When the response delay has elapsed, the alarm relays switch and the alarm LEDs light. If the measuring value exceeds or falls below the release value (response value plus hysteresis) after the alarm relays have switched, the selected release delay "t_{off}" begins. When "t_{off}" has elapsed, the alarm relays switch back to their original state. If the fault memory is activated, the alarm relays remain in alarm state until the reset button R is pressed.

Energy backup

Also in the event of complete power failure of the system being monitored, the delay times are effective during the energy backup time. If the fault memory is set to continuous mode, the alarm parameters remain stored, even on failure of the supply voltage.

Preset function

After connecting the device for the first time, the nominal system voltage will be determined (PrE run), and the response values for overvoltage and undervoltage as well as for under-frequency and overfrequency will automatically be set. When no voltage is determined within a system voltage range (PrE run), the response values will be set to the minimum or maximum voltage. In this case, the message "AL not SET" appears on the display. As long as no key is pressed, a nominal system voltage is being searched cyclically (PrE run). If a key is pressed, the search will be interrupted and the message "AL not SET" disappears. In this case, the appropriate response values have to be set in the menu. When activating the frequency monitoring function, the preset frequency will automatically be applied.



Operating elements

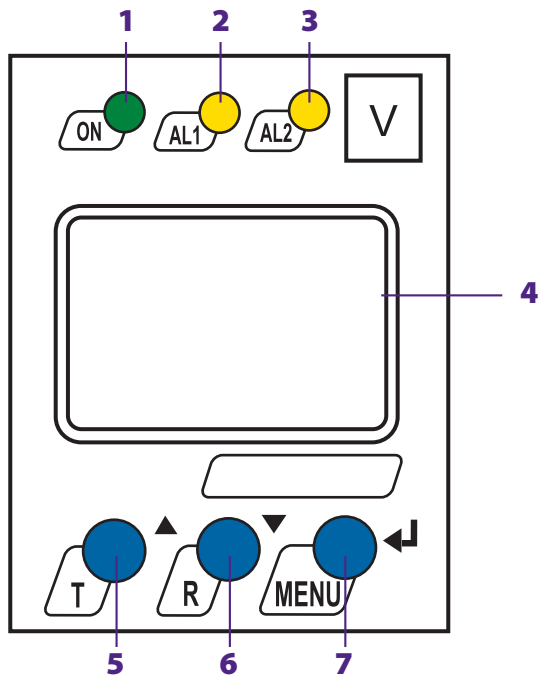

- 1 - Power On LED "ON" (green), lights when the supply voltage is applied and flashes in the event of system fault alarm.
- 2 - Alarm LED "AL1" (yellow), lights when the set response value $> U / < f / > f > f / \text{Asy} / \text{PHS}$ is exceeded and flashes in the event of system fault alarm.
- 3 - Alarm LED "AL2" (yellow), lights when the set response value $< U / < f / > f / \text{Asy} / \text{PHS}$ is exceeded and flashes in the event of system fault alarm.
- 4 - Multi-functional LC display.
- 5 - Test button "T": UP key: To change the measured value display, move upwards in the menu or change parameters.
To call up the self test: Press the key > 1.5 s.
- 6 - Reset button "R": DOWN key: To change the measured value display, move downwards in the menu or change parameters.
To delete stored insulation fault alarms: Press the key > 1.5 s.
- 7 - MENU key: Enter key: To confirm the measured value display or change parameters.
To call up the menu system: Press the key > 1.5 s.
Press the ESC key > 1.5 s: to abort an action or to return to the previous menu level.

Wiring diagram

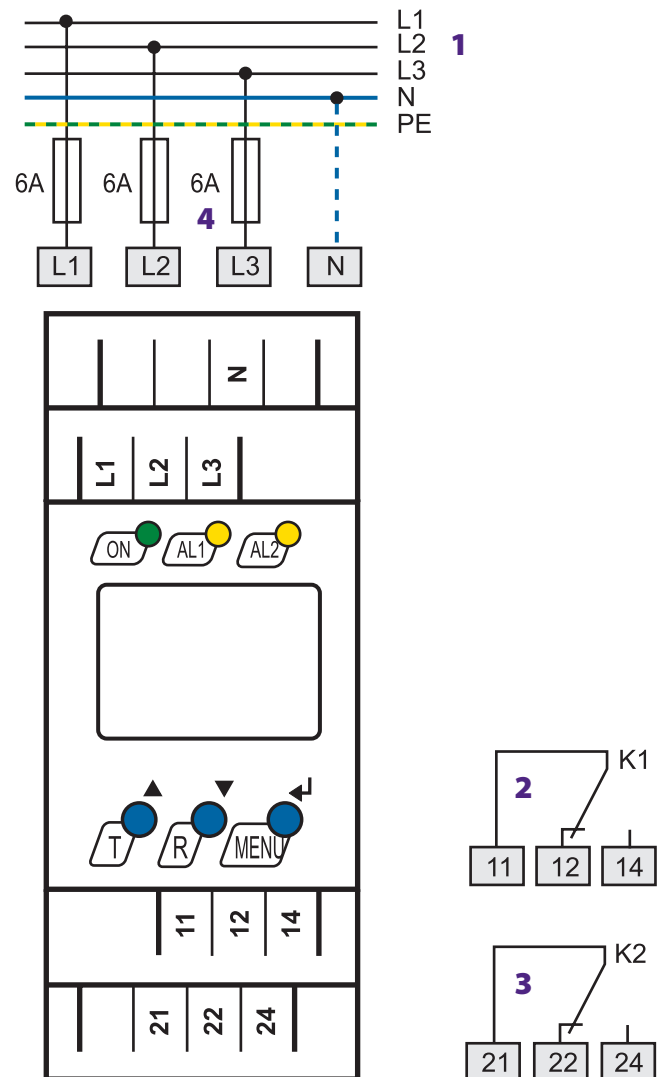

- 1 - Connection to the AC system/load to be monitored:
- 2 - Alarm relay K1: Configurable $f < U / > U / < f / > f / \text{Asy} / \text{PHS} / \text{ERROR}$
- 3 - Alarm relay K2: Configurable $f < U / > U / < f / > f / \text{Asy} / \text{PHS} / \text{ERROR}$
- 4 - Fuse as line protection.
A 6 A fuse is recommended. If being supplied from an IT system, both lines have to be protected by a fuse.

Ordering information

Type	Supply voltage U_S	Nominal system voltage U_n^*	Display range	Response value	Art. No.
VMD421H-D-3	--	3(N)AC 42...460 Hz / 70...500 V	AC 70...500 V	AC 70...500 V	B 9301 0007

*Absolute values

Accessories

Type	Art No.
Mounting clip for screw fixing (1 piece per device)	B 9806 0008

Timing diagram voltage monitoring

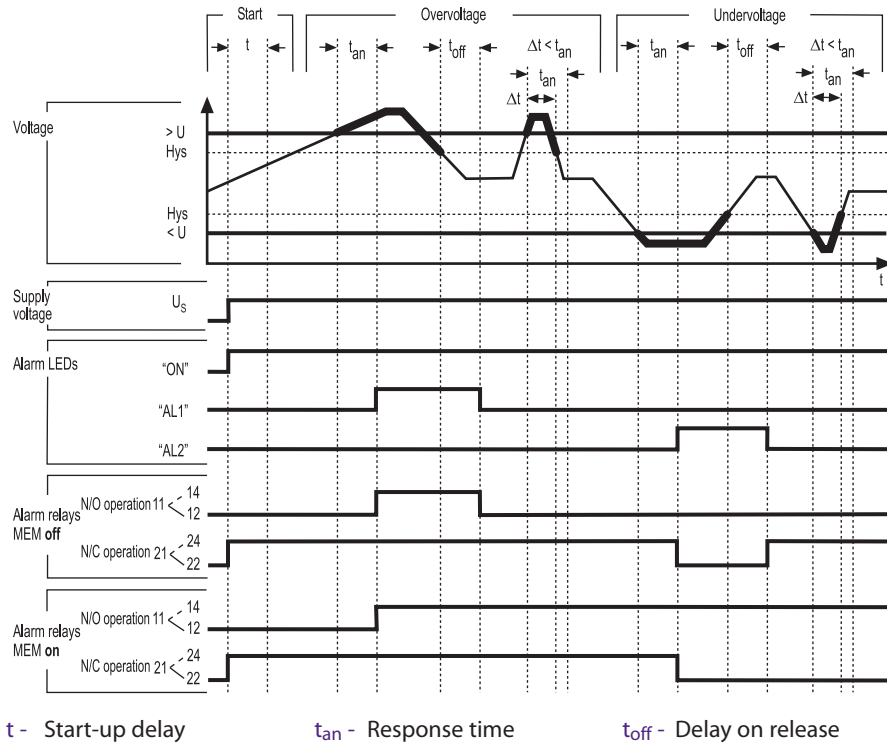

Zeitdiagramm Phasenausfall, Phasenfolge, Asymmetrie

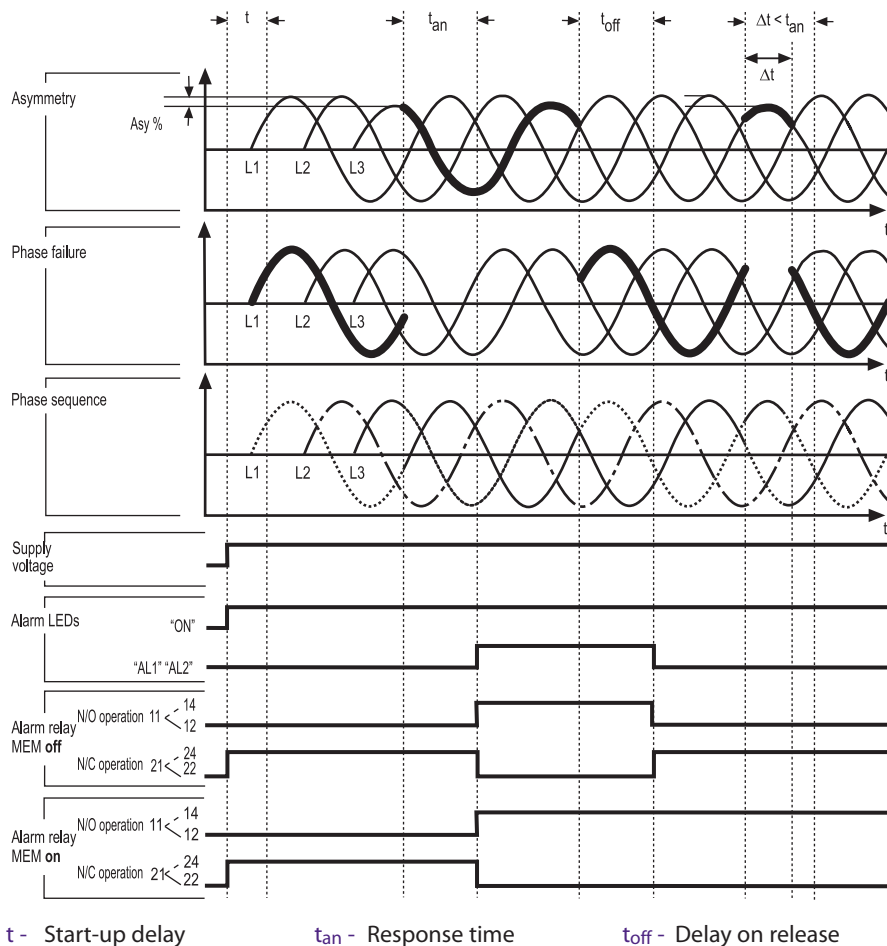

Dimension diagram XM421/ Mounting position Dimensions in mm

Open the front plate cover in direction of arrow!
Allow sufficient air flow through the ventilation slots!

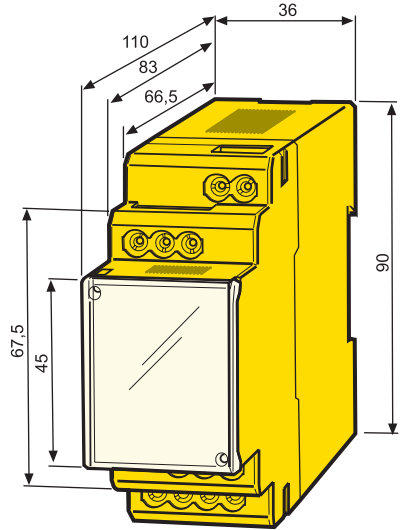

Screw mounting/Mounting position

Note: The upper mounting clip must be ordered separately (see ordering information).

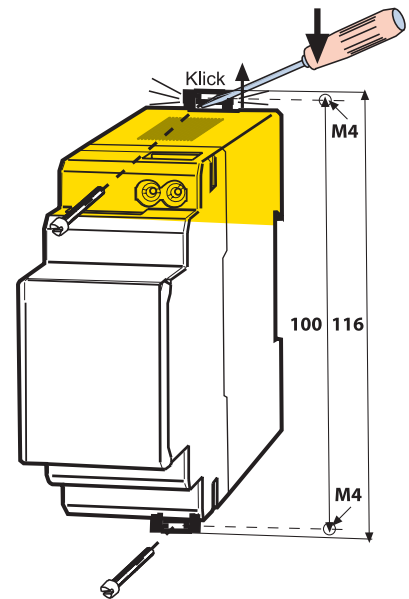

3.1

Technical data relay VMD421H for undervoltage, overvoltage and frequency monitoring
Insulation coordination acc. to IEC 60664-1 / IEC 60664-3

Rated insulation voltage	400 V
Rated impulse voltage/pollution degree	4 kV / III
Protective separation (reinforced insulation) between (N, L1, L2, L3) - (11, 12, 14) - (21, 22, 24)	
Voltage test acc. to IEC 61010-1:	
(N, L1, L2, L3) - (11, 12, 14)	3.32 kV
(N, L1, L2, L3) - (21, 22, 24)	2.21 kV

Supply voltage

Supply voltage U_S	none (internally supplied by U_n)
Power consumption	≤ 5 VA

Measuring circuit

Measuring range (r.m.s. value) (L-N)	AC 0...288 V
Measuring range (r.m.s. value) (L-L)	AC 0...500 V
Rated frequency f_n	15...460 Hz
Frequency display range	10...500 Hz

Response values

Type of distribution system	3(N) AC / 3 AC (3 AC)*
Undervoltage $< U$ (Alarm 2) (measuring method: 3Ph / 3n)	AC 70...500 V / 70...288 V
Overvoltage $> U$ (Alarm 1) (measuring method: 3Ph / 3n)	AC 70...500 V / 70...288 V
Resolution of setting U	1 V
Preset function for 3 AC measurement:	
Undervoltage $< U$ (0.85 U_n)* for $U_n = 400$ V / 208 V	340 V / 177 V
Overvoltage $> U$ (1.1 U_n)* for $U_n = 400$ V / 208 V	440 V / 229 V
Preset function for 3(N)AC measurement:	
Undervoltage $< U$ (0.85 U_n)* for $U_n = 230$ V / 120 V	196 V / 102 V
Overvoltage $> U$ (1.1 U_n)* for $U_n = 230$ V / 120 V	253 V / 132 V
Asymmetry	5...30 % (30 %)*
Phase failure	by setting of the asymmetry
Phase sequence	clockwise / anticlockwise rotation (off)*
Relative percentage error, voltage at 50 Hz / 60 Hz	± 1.5 %, ± 2 digits
Relative percentage error in the voltage range 15...460 Hz	± 3 %, ± 2 digits
Hysteresis U	1...40 % (5 %)*
Underfrequency $< Hz$	10...500 Hz
Overfrequency $> Hz$	10...500 Hz
Resolution of setting f 10.0...99.9 Hz	0.1 Hz
Resolution of setting f 100...500 Hz	1 Hz
Preset function:	
Underfrequency for $f_n = 16.7$ Hz / 50 Hz / 60 Hz / 400 Hz	16.2 Hz / 49.5 Hz / 59.5 Hz / 399 Hz
Overfrequency for $f_n = 16.7$ Hz / 50 Hz / 60 Hz / 400 Hz	17.2 Hz / 50.5 Hz / 60.5 Hz / 401 Hz
Hysteresis frequency Hys Hz	0.2...2 Hz (0.2 Hz)*
Relative percentage error in the frequency range 15...460 Hz	± 0.2 %, ± 1 digits

Specified time

Start-up delay t	0...99 s (0 s)*
Response delay $t_{on1/2}$	0...99 s (0 s)*
Delay on release t_{off}	0...99 s (0.5 s)*
Operating time voltage t_{ae}	140 ms
Operating time frequency t_{ae}	335 ms
Response time t_{an}	$t_{an} = t_{ae} + t_{on1/2}$
Discharging time energy backup on power failure	2.5 s
Charging time energy storage	60 s
Recovery time t_b	≤ 300 ms

Displays, memory

Display	LC display, multi-functional, not illuminated				
Display range measured value	AC/DC 0...500 V				
Operating error, voltage at 50 Hz / 60 Hz	± 1.5 %, ± 2 digits				
Relative percentage error in the voltage range 15...460 Hz	± 3 %, ± 2 digits				
Relative percentage error in the frequency range 15...460 Hz	± 0.2 %, ± 1 digits				
History memory (His) for the first alarm value	data record measured values				
Password	off / 0...999 (off)*				
Fault memory (M) alarm relay	on / off / con (on)*				
Switching elements					
Number of changeover contacts	2 x 1 (K1, K2)				
Operating principle	N/C operation n.c. or N/O operation n.o.				
	K2: Err, $< U$, $> U$, Asy, $< Hz$, $> Hz$, PHS (undervoltage $< U$, asymmetry Asy, N/C operation n.c.)*				
	K1: Err, $< U$, $> U$, Asy, $< Hz$, $> Hz$, PHS (overvoltage $> U$, asymmetry Asy, N/O operation n.o.)*				
Electrical service life under rated operating conditions, number of cycles	10 000				
Fault memory	on / off (on)*				
Contact data acc. to IEC 60947-5-1:					
Utilization category	AC 13	AC 14	DC-12	DC-12	DC-12
Rated operational voltage	230 V	230 V	24 V	110 V	220 V
Rated operational current	5 A	3 A	1 A	0.2 A	0.1 A
Minimum contact load	1 mA at AC / DC 10 V				

Environment / EMC

EMC	IEC 61326-1				
Operating temperature	-25 °C... $+55$ °C				
Classification of climatic conditions acc. to IEC 60721:					
Stationary use (IEC 60721-3-3)	3K5 (except condensation and formation of ice)				
Transport (IEC 60721-3-2)	2K3 (except condensation and formation of ice)				
Storage (IEC 60721-3-1)	1K4 (except condensation and formation of ice)				
Classification of mechanical conditions acc. to IEC 60721:					
Stationary use (IEC 60721-3-3)	3M4				
Transport (IEC 60721-3-2)	2M2				
Storage (IEC 60721-3-1)	1M3				

Connection

Connection	screw terminals				
Connection properties:					
rigid / flexible / conductor sizes	0.2...4 / 0.2...2.5 mm ² / AWG 24...12				
Multi-conductor connection (2 conductors with the same cross section):					
rigid/flexible	0.2...1.5 mm ² / 0.2...1.5 mm ²				
Stripping length	8...9 mm				
Tightening torque	0.5...0.6 Nm				

Other

Operating mode	continuous operation				
Mounting position	vertically, see dimension diagram				
Degree of protection, internal components (IEC 60529)	IP30				
Degree of protection, terminals (IEC 60529)	IP20				
Enclosure material	polycarbonate				
Flammability class	UL94 V-0				
DIN rail mounting acc. to	IEC 60715				
Screw fixing	2 x M4 with mounting clip				
Product standard	IEC 61010-1 and according to IEC 60255-6				
Operating manual	TGH1405				
Weight	≤ 240 g				

(*) = factory setting