

Residual current monitor RCMA472LY

AC / DC sensitive residual current monitor
for TN and TT systems
(AC, DC and pulsed DC currents)



RCMA472LY

Device features

- External measuring current transformer
- Two response values:
Alarm $I_{\Delta n1}$: 30...500 mA (0...1000 Hz)
Prewarning $I_{\Delta n2}$: 50 % / 100 % of $I_{\Delta n1}$
- Adjustable response delay 0...10 s (prewarning 0 / 1 s)
- Two separate alarm relays with one changeover contact each
- N/O or N/C operation
- Fault memory
- Combined TEST and RESET button
- Connection external TEST and RESET button
- LED bar graph indicator $I_{\Delta n}$ 0...100 %
- Connection external measuring instrument $I_{\Delta n1}$ 0...100 %
- CT connection monitoring
- Sealable transparent cover
- Separate supply voltage
- Type B acc. to IEC 60755
- RoHS conform

Approvals



Product description

The AC/DC sensitive residual current monitor RCMA472LY is designed for monitoring earthed power supply systems (TN and TT systems) where DC fault currents or residual currents continuously greater than zero may occur. These are in particular loads containing six-pulse rectifiers or one way rectifiers with smoothing, such as converters, battery chargers, construction site equipment with frequency-controlled drives.

The prewarning stage (50 % of the set response value $I_{\Delta n1}$) allow to distinguish between prewarning and alarm. Since the values are measured with measuring current transformers, the device is nearly independent of the load current and the nominal voltage of the system.

Application

- AC/DC sensitive residual current monitoring in earthed two, three or four conductor systems.
- AC/DC sensitive current monitoring of single conductors de-energized under normal conditions (e. g. N and PE conductors).
- Variable-speed drives
- Uninterruptible power supply systems (UPS)
- MF welding systems

Function

Residual current monitoring takes place via an external measuring current transformer. When the current respectively the residual current exceeds the set response value, the alarm LED lights and the associated alarm relay switches when the set response delay has elapsed.

The alarm messages are stored. The fault memory can be reset by pressing the RESET button. The device function can be tested using the TEST button.

The currently measured value in per cent related to the set response value is shown on the LED bar graph indicator. The CT circuit is continuously monitored. In case of wire breakage, the alarm relay switches and the Power On LED flashes.

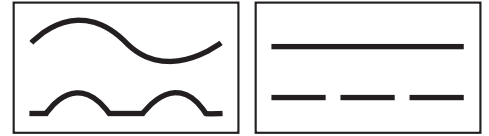

Wiring diagram – system connection, external connections

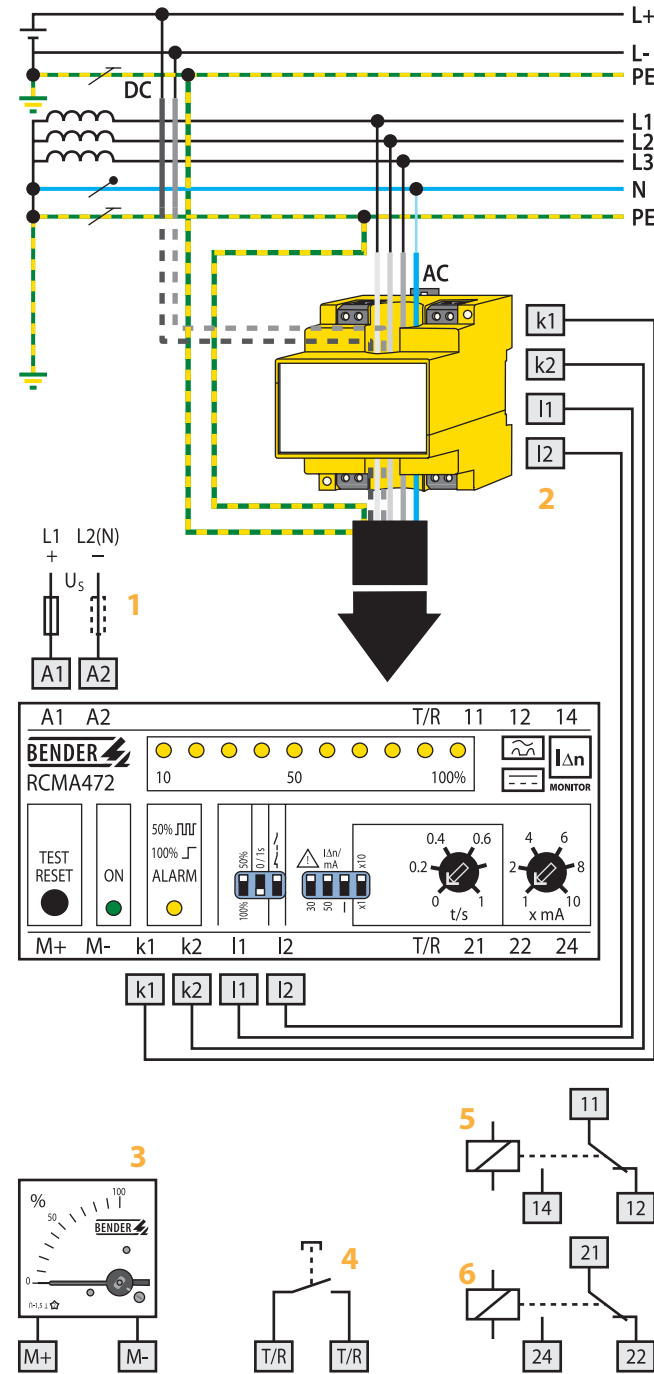

- 1 - Supply voltage U_S (see ordering information), a 6 A fuse recommended for line protection.
- 2 - External measuring current transformer W465-A26
- 3 - External measuring instrument
- 4 - External TEST and RESET button
- 5 - Alarm relay: switches when the fault current exceeds the response value $I_{\Delta n1}$ (alarm) and in case of interruption of the CT connection.
- 6 - Alarm relay: switches when the fault current exceeds 50 % or 100 % of the response value $I_{\Delta n1}$

Do not route the PE conductor through the measuring current transformer!

Wiring diagram – front plate

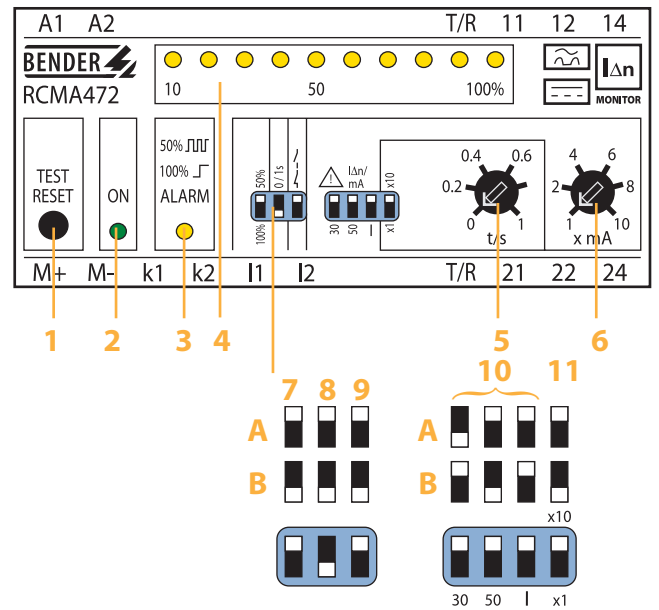

- 1 - Combined TEST and RESET button: short-time pressing (< 1 s) = RESET, long-time pressing (> 2 s) = TEST.
 - 2 - Power On LED: lights when the device is in operation and flashes in case of interruption of the CT connection, defective CT or when the measuring range is exceeded.
 - 3 - Alarm LED: lights when the fault current exceeds the set response value and flashes when 50 % of the set response value are reached.
 - 4 - LED bar graph indicator, shows the measuring value in per cent related to the preset response value.
 - 5 - Potentiometer for setting the response delay (0...1 s)
 - 6 - Potentiometer for setting the response value ($\times 1 \dots 10$ mA)
- Response range (DIP switch white = switch position)
- 7 - Contact 21-22-24 (prewarning)
 - A - at 50 % of $I_{\Delta n1}$
 - B - at 100 % of $I_{\Delta n1}$
 - 8 - Response delay prewarning
 - A - Delay 1 s
 - B - Delay 0 s
 - 9 - Operating principle of the alarm relay
 - A - N/O operation
 - B - N/C operation
 - 10 - Setting of the response range
 - A - 30 mA
 - B - 50 mA
 } $\times 1 \dots 10$
 - 11 - Setting of the response delay
 - A - Setting value $\frac{1}{5} \times 10$
 - B - Setting value $\frac{1}{5} \times 1$

Technical data residual current monitor RCMA472LY

Insulation coordination acc. to IEC 60664-1	
Rated insulation voltage	AC 250 V
Rated impulse voltage / pollution degree	4 kV / 3
Voltage ranges	
Supply voltage U_S	see ordering information
Operating range of U_S	0.85...1.1 x U_S
Frequency range of U_S	DC / 50...60 Hz
Power consumption	≤ 3.5 VA
Measuring circuit / response values	
External measuring current transformer	W465-A26
Operating characteristic acc. to IEC 60755	Type B
Rated residual operating current $I_{\Delta n2}$ (prewarning)	50 / 100 % of $I_{\Delta n1}$
Response delay t_v	0 / 1 s
Rated residual operating current $I_{\Delta n1}$ (alarm)	30...500 mA
Response delay t_v , adjustable	0...10 s
Rated frequency	0...1000 Hz
Relative percentage error	0...-25 %
Hysteresis	approx. 25 % of the response value
Response time t_{an} at $I_{\Delta n1} = 1 \times I_{\Delta n1} / 2$ ($t_v = 0$ s)	< 70 ms
Response time t_{an} at $I_{\Delta n1} = 5 \times I_{\Delta n1} / 2$ ($t_v = 0$ s)	< 40 ms
Displays	
LED bar graph indicator	0...100 %
LEDs	Power On, prewarning, alarm
Inputs/outputs	
TEST and RESET button	internal / external
Cable length external TEST and RESET button	≤ 10 m
Current source for external measuring instrument 0...100 %	DC 0...400 μ A
Load	≤ 12.5 k Ω
Cable lengths for measuring current transformers	
Single wire ≥ 0.75 mm ²	0...10 m
Switching elements	
Number of switching elements	2 x 1 changeover contact
Operating principle, adjustable	N / C operation / N / O operation
Electrical endurance, number of cycles	12000
Rated contact voltage	AC 250 V / DC 300 V
Limited making capacity	AC / DC 5 A
Breaking capacity	2 A, AC 230 V, cos phi = 0,4 0.2 A, DC 220 V, L / R = 0.04 s
Fault memory	ON
General data	
EMC immunity	acc. to EN 61543
EMC emission	acc. to EN 61000-6-4
Shock resistance IEC 60068-2-27 (during operation)	15 g / 11 ms
Bumping IEC 60068-2-29 (during transport)	40 g / 6 ms
Vibration resistance IEC 60068-2-6 (during operation)	1 g / 10...150 Hz
Vibration resistance IEC 60068-2-6 (during transport)	2 g / 10...150 Hz
Ambient temperature, during operation	-25 °C...+70 °C
Ambient temperature, when stored	-40 °C...+75 °C
Climatic category IEC 60721-3-3	3K5
Operating mode	continuous operation
Mounting	any position
Connection	screw terminals
Connection properties	
rigid / flexible	0.2...4 / 0.2...2.5 mm ²
flexible with ferrules without / with plastic collar	0.25...2.5 mm ²
Conductor sizes (AWG)	24...12
Protection class, internal components (IEC 60529)	IP30
Protection class, terminals (IEC 60529)	IP20
Type of enclosure	X470
Enclosure material	polycarbonate
Screw mounting	2 x M4
DIN rail mounting acc. to	IEC 60715
Flammability class	UL94V-0
Standards	IEC 62020
Instruction leaflet	BP404002
Weight	≤ 350 g

Ordering information

Type	Response range $I_{\Delta n}$	Rated frequency	Time delay	Measuring current transformers	Display	Fault memory	Supply voltage U_S	Art. No.
RCMA472LY	30...500 mA	0...1000 Hz	0...10 s	W465-A26	internal / external	×	AC 230 V	B 9404 2007 ²⁾
RCMA472LY-13	30...500 mA	0...1000 Hz	0...10 s	W465-A26	internal / external	×	AC 90...132 V*	B 9404 2037 ²⁾
RCMA472LY-21	30...500 mA	0...1000 Hz	0...10 s	W465-A26	internal / external	×	DC 9.6...84V*	B 9404 2012 ¹⁾
RCMA472LY-23	30...500 mA	0...1000 Hz	0...10 s	W465-A26	internal / external	×	DC 77...286V*	B 9404 2013 ¹⁾

Other supply voltages on request

* Absolute values of the operating range

¹⁾ For industrial application only

²⁾ For industrial and household applications

Accessories

External measuring current transformer

Type	Inside diameter (mm)	$I_{\Delta n}$	Art. No.
W465-A26	$\varnothing 23$	$\geq 30 \text{ mA}$	B 911 754





External measuring instrument

Type	Display range	Size (mm)	Art. No.
9604-4241	0...100 %	96 x 96	B 986 807

Measuring converter

Type	Input	Output	Art. No.
RK170	0...400 μA	0...10 V / 0/4...20 mA	B 9804 1500

Conditions of operation according to IEC 62020, IEC 60755 amendment 2, Type B

Type of current	Wave form	Tripping current
Alternating currents (50 Hz)		$0,5...1 \times I_{\Delta n}$
Pulsed DC residual currents (positive and negative half waves) half-wave current		$0,5...1,4 \times I_{\Delta n}$
Phase-controlled half-wave currents AC current delay angle $90^\circ \text{ el}...135^\circ \text{ el}$		$0,5...1,4 \times I_{\Delta n}$
Half-wave current superimposed by a smooth direct current of 6 mA		$0,5...1,4 \times I_{\Delta n}$
Smooth DC residual current		$0,5...2 \times I_{\Delta n}$

Dimension diagram X470

Dimensions in mm

