

## Ground fault monitor RCM420

Ground Fault Monitor / Relay  
for Grounded AC Systems



RCM420

### Device features

- Ground fault monitoring for pure AC grounded systems
- True RMS value measurement (AC)
- External measuring current transformer
- Two separately adjustable response values
- Frequency range 42...2000 Hz
- 3 separately adjustable time delays: start-up, response, and release
- Restart function
- LCD screen with real-time value display
- Latching or non-latching operating mode
- CT connection monitoring
- Power On LED, LED Alarm 1 / 2
- TEST / RESET button, internal / external
- Two separate voltage-free SPDT contacts
- Selectably operates normally energized or normally deenergized
- Password protection
- Device self monitoring
- Sealable transparent cover
- Two-module enclosure (36 mm)
- Conforms to RoHS

### Approvals



### Product description

The RCM420 monitors for ground faults in grounded and high-resistance grounded AC systems, both single- and three-phase. The RCM420 is specially designed to provide advanced warning of developing ground faults without the problems associated with high sensitivity nuisance tripping.

A digital LCD screen displays real-time measurements of the system's ground fault current. Two separately adjustable SPDT contacts allow for information transmission (such as to a PLC) or power interruption (such as through a contactor or shunt trip breaker).

Since the values are measured with measuring current transformers, the device is nearly independent of the load current and the nominal voltage of the system.

### Applications

- Ground fault detection in single- or three-phase AC systems
- Motor and motor control systems
- Heat tracing systems
- Current monitoring of normally offline single conductors
- Alarm systems, safety devices
- Air conditioning systems
- Cooling equipment with valuable frozen goods
- Generators, portable and fixed
- Industrial controls

### Function

Once the supply voltage  $U_S$  is applied, the starting delay ("t") activates. Alarms during this delay will not cause the RCM420 to switch over the contacts.

Measurements of the system's ground fault current are taken via an external current transformer. All phases (including the neutral if one exists) are placed through the current transformer. The measured value is indicated in real-time on the device's LCD display.

If the measured value exceeds one or both response values, the respective response delays  $t_{on1/2}$  activate. If the ground fault still exists after the response delays expire, the respective contacts switch over and the alarm LEDs activate. If the device is set to non-latching mode and the ground fault clears, the alarms will clear after the set release time "t<sub>off</sub>" expires. If the device is set to latching mode, the alarms will not clear until the device is reset manually or the supply voltage is lost. The TEST function allows for an internal operation testing of the device. The device's easy-to-use onboard menu manages all settings via the detailed LCD screen. An optional password protection setting protects unauthorized users from changing settings.

### Connection monitoring

The connections between the device and the external current transformer are continuously monitored. If the device detects a connection error, the CT connection monitoring alarm will activate, and the contacts will switch over without delay. After the connection error is cleared, the device will reset based on its latching/non-latching setting.

### Restart function

If an alarm is pending after resetting the alarm relay and restarting the system being monitored, this reset process is repeated until the preset number of restart cycles is completed. As soon as the preset number of restart cycles is completed, the fault memory is set to ON.

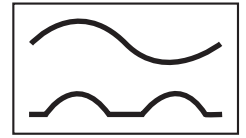

Operating and display elements

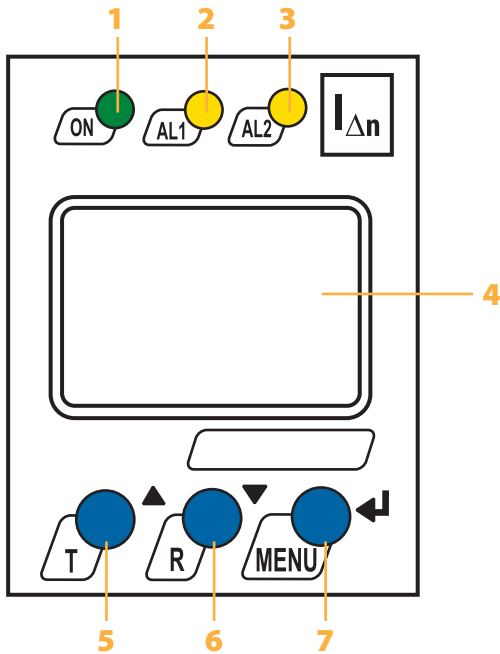

- 1 - Power "ON" LED (green): Illuminates when power is received to the unit. Flashes when the current transformer connection alarm is active.
- 2 - Alarm LED "AL1" (yellow): Alarm 1, illuminates when the set response value  $I_{\Delta n1}$  has been exceeded. Flashes when the current transformer connection alarm is active.
- 3 - Alarm LED "AL2" (yellow): Alarm 2, illuminates when the set response value  $I_{\Delta n2}$  has been exceeded. Flashes when the current transformer connection alarm is active.
- 4 - Multi-functional LCD display
- 5 - TEST button: Activates self-test  
Arrow up key: Scrolls up inside device's menu
- 6 - RESET button: Resets device  
Arrow down key: Scrolls down inside device's menu
- 7 - MENU key: Activates device's internal menu  
Enter key: Confirm change inside device's menu  
Escape key (held > 1.5 s): Goes back a step inside menu

Wiring diagram

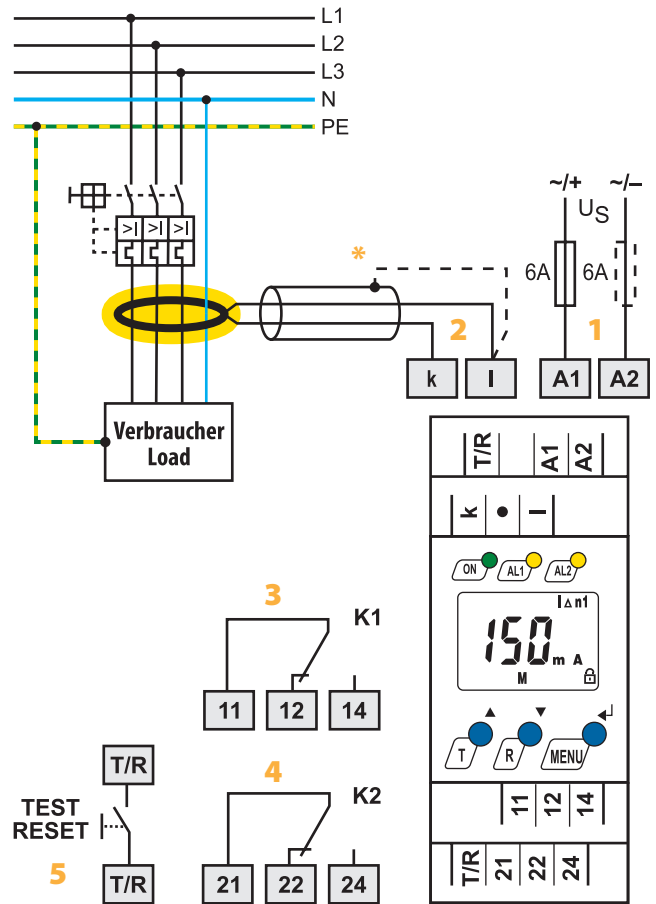

- 1 - External supply voltage used to power device  
a 6 A fuse recommended for internal short circuit protection.
- 2 - Connection to external current transformer. All phases, including the neutral if one exists, are placed through the current transformer.
- 3 - Alarm relay K1: programmable for  $I_{\Delta n1}$  /  $I_{\Delta n2}$  / TEST / ERROR
- 4 - Alarm relay K2: programmable for  $I_{\Delta n1}$  /  $I_{\Delta n2}$  / TEST / ERROR
- 5 - Combined external TEST and RESET button
- \* - When shielded cabling is used.

**Note: Do not route the ground conductor through the measuring current transformer when also routing the power conductors!**

## Technical data

### Insulation coordination acc. to IEC 60664-1 / IEC 60664-3

Rated insulation voltage	250 V
Rated impulse voltage / pollution degree	2.5 kV / III
Protective separation (reinforced insulation) between (A1, A2) - (k / I, T / R) - (11, 12, 14) - (21, 22, 24)	
Voltage test according to IEC 61010-1	2.21 kV

### Supply voltage

Supply voltage $U_s$	see ordering details
Power consumption	$\leq 3$ VA

### Measuring circuit

External measuring current transformer	W... , WR... , WS... series
Load	68 $\Omega$
Rated insulation voltage (measuring current transformer)	800 V
Operating characteristic acc. to IEC 62020	Type A
Rated frequency	42...2000 Hz
Measuring range	3 mA...16 A
Relative percentage error	0...-20 %
Display accuracy	$\pm 15$ %

### Response values

Rated residual operating current $I_{\Delta n1}$ (prewarning)	50...100 % $\times I_{\Delta n2}$ (50 %)*
Rated residual operating current $I_{\Delta n2}$ (alarm)	10 mA...10 A (30 mA)*
Hysteresis	10...25 % (15 %)*

### Specified time

Starting delay t	0...10 s (0,5 s)*
Response delay $t_{on2}$ (alarm)	0...10 s (0 s)*
Response delay $t_{on1}$ (prewarning)	0...10 s (1 s)*
Delay on release $t_{off}$	0...99 s (1 s)*
Operating time $t_{ae}$ at $I_{\Delta n} = 1 \times I_{\Delta n1} / 2$	$\leq 180$ ms
Operating time $t_{ae}$ at $I_{\Delta n} = 5 \times I_{\Delta n1} / 2$	$\leq 30$ ms
Response time $t_{an}$	$t_{an} = t_{ae} + t_{on1} / 2$
Recovery time $t_b$	$\leq 300$ ms
Number of restart cycles	0...100 (0)*

### Cable lengths for measuring current transformers

Single wire $\geq$ AWG 20 (0.75 mm <sup>2</sup> )	0...3.2 ft (0...1 m)
Single wire, twisted $\geq$ AWG 20 (0.75 mm <sup>2</sup> )	0...32.8 ft (0...10 m)
Shielded cable $\geq$ AWG 22 (0.5 mm <sup>2</sup> )	0...131 ft (0...40 m)
Recommended cable (shielded, shield on one side connected to terminal I of the RCM420, not connected to earth)	J-Y(ST)Y min. 2 $\times$ 0.8
Connection	screw terminals

### Displays, memory

Display range, measuring value	3 mA...16 A
Relative percentage error	0...-30 % / $\pm 2$ digit
Measured-value memory for alarm value	data record measured values
Password	off / 0...999 (off)*
Fault memory behavior	ON / OFF (Latching / Non-latching)

### Inputs / outputs

Cable length for external test / reset button	0...10 m
---	----------

### Switching elements

Number of switching elements	2 SPDT contacts				
Operating principle	normally energized or normally deenergized(*)				
Electrical service life under rated operating conditions	10.000 switching operations				
Contact data acc. to IEC 60947-5-1					
Utilization category	AC-13	AC-14	DC-12	DC-12	DC-12
Rated operational voltage	230 V	30 V	24 V	110 V	220 V
Rated operational current	5 A	3 A	1 A	0.2 A	0.1 A
Minimum contact load	1 mA at AC / DC $\geq 10$ V				

### Environment / EMC

EMC	IEC 62020: 2003-11				
Operating temperature	-25 °C...+55 °C				
Climatic class acc. to IEC 60721					
Stationary use (IEC 60721-3-3)	3K5 (except condensation and formation of ice)				
Transport (IEC 60721-3-2)	2K3 (except condensation and formation of ice)				
Long-time storage (IEC 60721-3-1)	1K4 (except condensation and formation of ice)				
Classification of mechanical conditions IEC 60721					
Stationary use (IEC 60721-3-3)	3M4				
Transport (IEC 60721-3-2)	2M2				
Long-time storage (IEC 60721-3-1)	1M3				

### Connection

Connection	screw terminals
rigid / flexible	AWG 24...12 / 24...14
Multi-conductor connection (2 conductors with the same cross section)	
rigid / flexible	AWG 24...14 / 24...14
Stripping length	8...9 mm
Tightening torque	0.5...0.6 Nm

### Other

Operating mode	continuous operation
Position of normal use	any
Degree of protection, internal components (IEC 60529)	IP30, NEMA 1
Degree of protection, terminals (IEC 60529)	IP20, NEMA 1
Enclosure material	polycarbonate
Flammability class	UL94V-0
DIN rail mounting acc. to	IEC 60715
Screw mounting	2 $\times$ M4 with mounting clip
Standards	IEC 62020
Instruction leaflet	TGH1410
Weight	$\leq 150$ g

( ) \* factory setting

**External measuring current transformers**

Type	Inside diameter (mm)	Art. No.
W20	∅ 20	B 9808 0003
W35	∅ 35	B 9808 0010
W60	∅ 60	B 9808 0018
W120	∅ 120	B 9808 0028
W210	∅ 210	B 9808 0034
WR70x175	70 x 175	B 9808 0609
WR115x305	115 x 305	B 9808 0610
WS20x30	20 x 30	B 9808 0601
WS50x80	50 x 80	B 9808 0603
WS80x120	80 x 120	B 9808 0606

Other measuring current transformer types on request.

**Accessories**

Type	Art. No.
Mounting clip for enclosure XM420 (1 piece per device)	B 9806 0008
Snap-on mounting for W20... / W35...	B 9808 0501
Snap-on mounting for W60...	B 9808 0502

**Dimension diagram XM420**

Dimensions in mm  
Open the front plate cover in direction of arrow!

Screw mounting

Note: The upper mounting clip must be ordered separately (see ordering information).

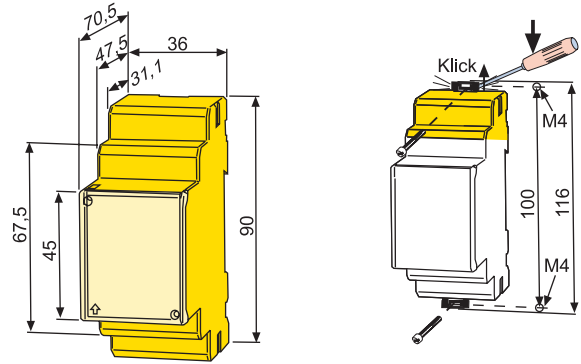

**Ordering information: RCM420 (standard models)**

Type	Response range I <sub>Δn</sub>	Frequency range	Measuring current transformers	Supply voltage U <sub>5</sub> *	Art. No.
RCM420-D-1	10 mA...10 A	42...2000 Hz	W..., WR..., WS...	DC 9.6...94 V / AC 42...460 Hz 16...72 V	B 9401 4001
RCM420-D-2	10 mA...10 A	42...2000 Hz	W..., WR..., WS...	DC 70...300 V / AC 42...460 Hz 70...300 V	B 9401 4002

\* absolute values

**Ordering information: RCM420 (ordering guide for all models)**

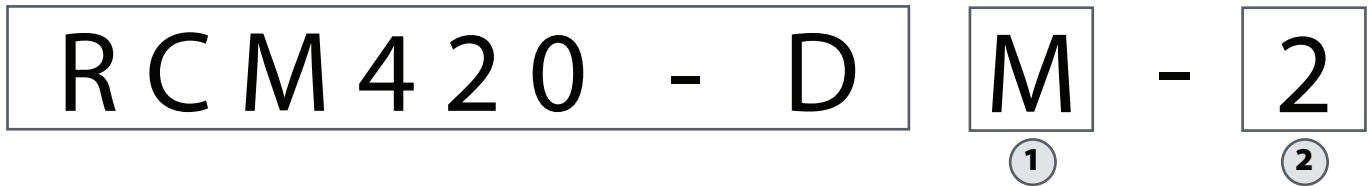

**Code 1: Contact / analog outputs (optional)**

Modifier	Contact 1	Contact 2
Nothing	Alarm contact	Alarm contact
"M"	All analog outputs*	--
"M1C"	0(4)...20 mA	Alarm contact
"M2C"	0...400 μA	Alarm contact
"M3C"	0...10 V	Alarm contact

\* selectable between 0(4)...20 mA, 0...400 μA, 0...10 V

**Code 2: Auxiliary supply voltage**

Modifier	Supply voltage U <sub>5</sub> *
"1"	DC 9.6...94 V / AC 42...460 Hz 16...72 V
"2"	DC 70...300 V / AC 42...460 Hz 70...300 V

\* absolute values