

RCMA420 Series

Digital Ground Fault Monitor / Ground Fault Relay

Grounded and High-Resistance Grounded AC/DC Systems



Ground fault monitor RCMA420

Ground Fault Monitor / Ground Fault Relay for Grounded AC, DC, and AC/DC Systems



RCMA420

Features

- Ground fault monitoring for AC, DC, and mixed AC/DC systems
- True RMS value measurement (AC + DC)
- Main alarm value, adjustable 10...500 mA
- Separate prewarning alarm value, adjustable to 50...100 % of the main alarm
- Frequency range 0...2000 Hz
- 3 separately adjustable time delays: start up, response, and release
- LCD screen with real-time value display
- Latching or non-latching operating mode
- CT connection monitoring
- Power On LED, LED Alarm 1 / 2
- TEST / RESET button, internal / external
- Two separate voltage-free SPDT contacts
- Selectably operates normally energized or normally de-energized
- Continuous self monitoring
- Password protection for device settings
- Sealable transparent cover
- Two-module enclosure (36 mm)
- Conforms to RoHS

Approvals



Description

The RCMA420 monitors for ground faults in grounded and high-resistance grounded AC (both single- and three-phase), DC, and mixed AC/DC systems. The RCMA420 is specially designed to provide advanced warning of developing ground faults without the problems associated with high sensitivity nuisance tripping.

A digital LCD screen displays real-time measurements of the system's ground fault current. Two separately adjustable SPDT contacts allow for information transmission (such as to a PLC) or power interruption (such as through a contactor or shunt trip breaker).

Since the values are measured with measuring current transformers, the device is nearly independent of the load current and the nominal voltage of the system.

Applications

- Ground fault detection in single- or three-phase AC systems
- Ground fault detection in pure DC or mixed AC/DC systems
- Motors and motor control systems
- Systems with variable frequency drives (VFDs)
- Battery backup systems and other pure DC systems

Function

Once the supply voltage U_S is applied, the startup delay ("t") activates. Alarms during this delay will not cause the RCMA420 to switch over the contacts.

Measurements of the system's ground fault current are taken via an external current transformer. For AC, all phases (including the neutral if one exists) are placed through the current transformer. For DC, both legs are placed through the current transformer. The measured value is indicated in real-time on the device's LCD display.

If the measured value exceeds one or both response values, the respective response delays $t_{on 1/2}$ activate. If the ground fault still exists after the response delays expire, the respective contacts switch over and the alarm LEDs activate. If the device is set to non-latching mode and the ground fault clears, the alarms will clear after the set release time "t_{off}" expires. If the device is set to latching mode, the alarms will not clear until the device is reset manually or the supply voltage is lost. The TEST function allows for an internal operation testing of the device. The device's easy-to-use onboard menu manages all settings via the detailed LCD screen. An optional password protection setting protects unauthorized users from changing settings.

Connection monitoring

The connections between the device and the external current transformer are continuously monitored. If the device detects a connection error, the CT connection monitoring alarm will activate, and the contacts will switch over without delay. After the connection error is cleared, the device will reset based on its latching/non-latching setting.

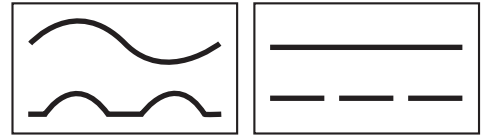

Front display and operating elements

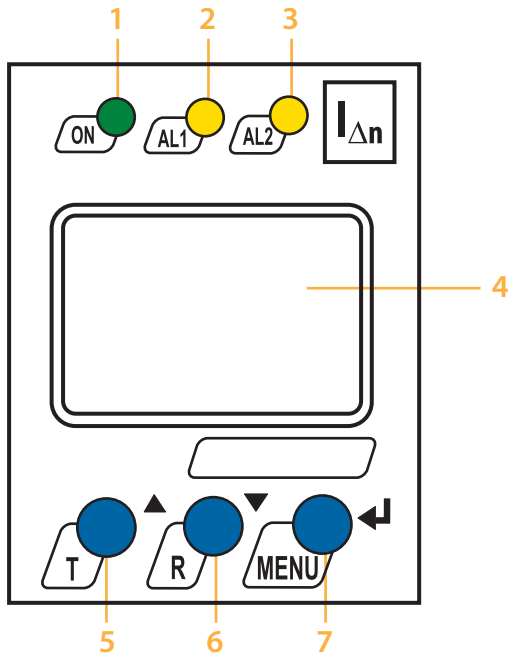

- 1 - Power "ON" LED (green): Illuminates when power is received to the unit. Flashes when the current transformer connection-alarm is active.
- 2 - Alarm LED "AL1" (yellow): Alarm 1, illuminates when the set response value $I_{\Delta n1}$ has been exceeded. Flashes when the current transformer connection alarm is active.
- 3 - Alarm LED "AL2" (yellow): Alarm 2, illuminates when the set response value $I_{\Delta n2}$ has been exceeded. Flashes when the current transformer connection alarm is active.
- 4 - Multi-functional LCD display
- 5 - TEST button: Activates self-test
Arrow up key: Scrolls up inside device's menu
- 6 - RESET button: Resets device
Arrow down key: Scrolls down inside device's menu
- 7 - MENU key: Activates device's internal menu
Enter key: Confirm change inside device's menu
Escape key (held > 1.5 s): Goes back a step inside menu

Wiring diagram

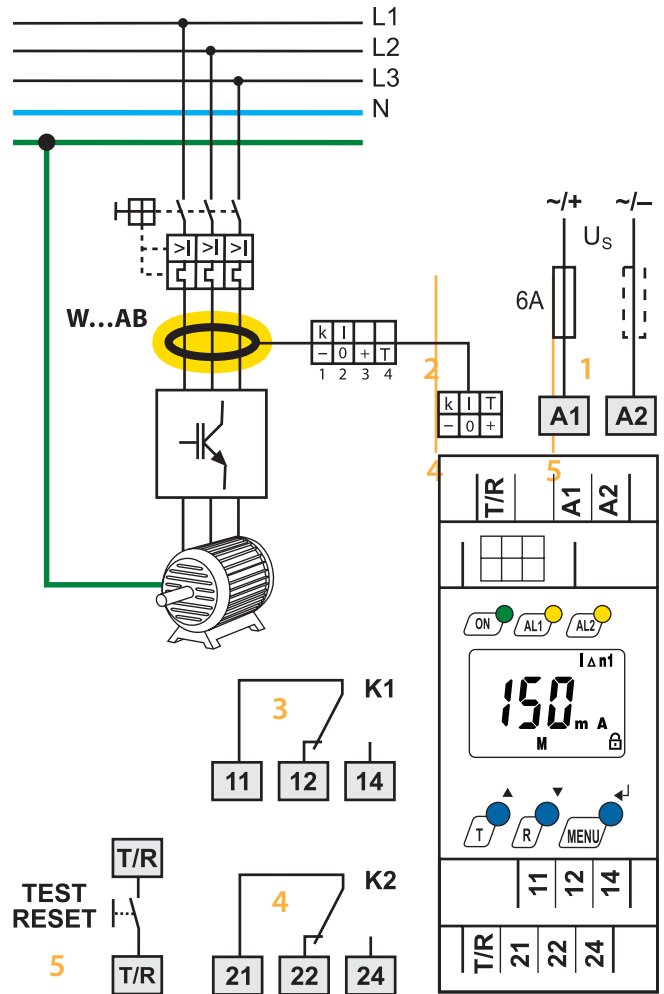

- 1 - External supply voltage used to power device
a 6 A fuse recommended for internal short circuit protection
- 2 - Connection to external current transformer. For AC, all phases (including a neutral if one exists) are placed through. For DC, both legs are placed through.
- 3 - Alarm relay K1: $I_{\Delta n1}$ (prewarning).
- 4 - Alarm relay K2: alarm $I_{\Delta n2}$ (alarm).
- 5 - Combined TEST and RESET button:
short depress (< 1.5 s) = RESET,
long depress (> 1.5 s) = TEST.

Note: Do not route the ground conductor through the measuring current transformer when also routing the power conductors!

Wiring diagram: External current transformer

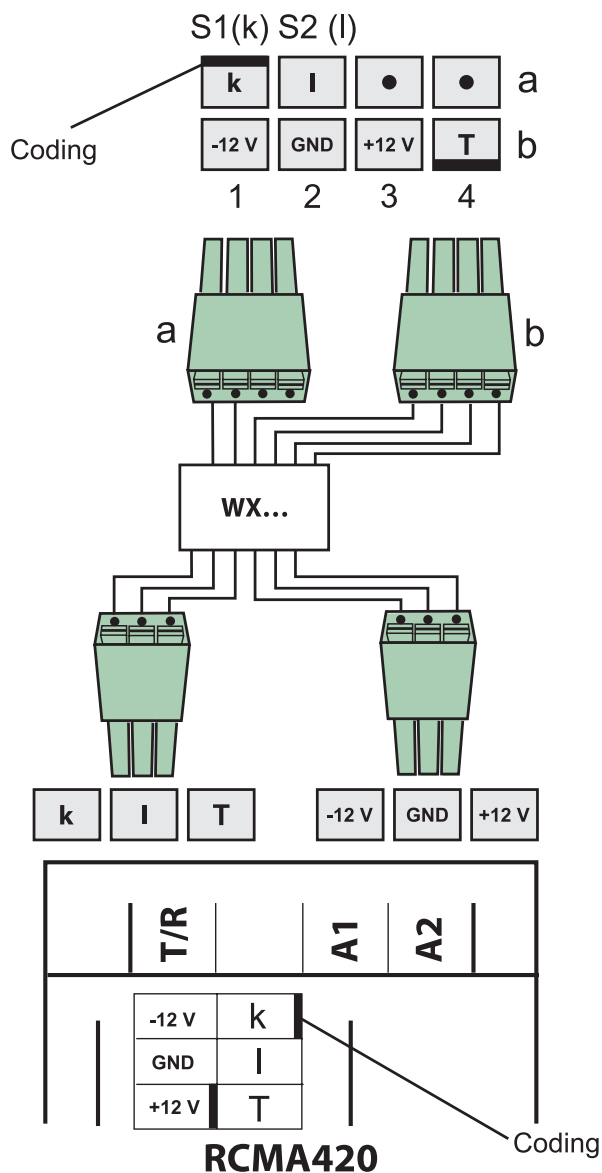
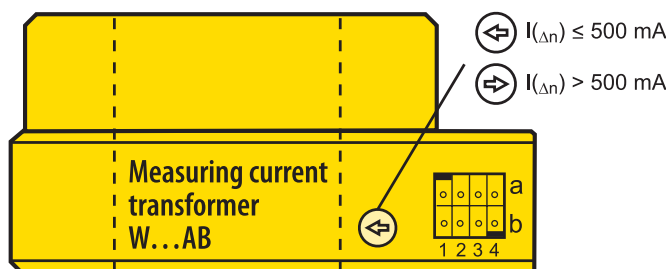

Dimensions

Open the front plate cover in direction of arrow.
Dimensions in inches

Screw mounting

Note: The upper mounting clip must be ordered separately (see ordering information).

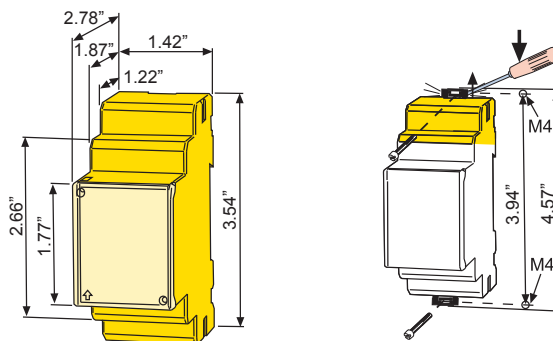

Ordering information: RCMA420 (standard models)

Type	Response range $I_{\Delta n}$	Frequency range	Supply voltage U_s^*	Art. No.
RCMA420-D-1	10...500 mA	0...2000 Hz	DC 9.6...94 V / AC 42...460 Hz 16...72 V	B 9404 3001
RCMA420-D-2	10...500 mA	0...2000 Hz	DC 70...300 V / AC 42...460 Hz 70...300 V	B 9404 3002

* Absolute values

External current transformers

Type	Inside diameter (mm)	Art. No.
W20AB	ø 20	B 9808 0008
W35AB	ø 35	B 9808 0016
W60AB	ø 60	B 9808 0026

CT connection cable

Type	Length / m	Art. No.
WX-100	1	B 9808 0503
WX-250	2.5	B 9808 0504
WX-500	5	B 9808 0505

Accessories

Type	Art. No.
Mounting clip for enclosure XM420	B 9806 0008
Snap-on mounting for W20... / W35...	B 9808 0501
Snap-on mounting for W60...	B 9808 0502

(1 unit required for each device)

Technical data

Insulation coordination acc. to IEC 60664-1 / IEC 60664-3

Rated insulation voltage	250 V
Rated impulse voltage / pollution degree	2.5 kV / III
Protective separation (reinforced insulation) between (A1, A2) – (k / l / - / 0 / +, T / R) – (11, 12, 14) – (21, 22, 24)	
Voltage test according to IEC 61010-1	2.21 kV

Supply voltage

Supply voltage U_s	see ordering information
Power consumption	≤ 3 VA

Measuring circuit

External measuring current transformer	W20AB, W35AB, W60AB series
Rated insulation voltage (measuring current transformer)	800 V
Operating characteristic acc. to IEC 60755	Type B
Rated frequency	0...2000 Hz
Measuring range	3...500 mA
Relative percentage error of measuring value	0...-35 %
Display accuracy of measuring value	± 17.5 %

Response values

Rated ground fault operating current $I_{\Delta n1}$ (prewarning)	50...100 % of $I_{\Delta n2}$ (15 mA)*
Rated ground fault operating current $I_{\Delta n2}$ (Alarm)	10...500 mA (30 mA)*
Hysteresis	10...25 % (15 %)*

Specified time

Starting delay t	0...10 s (0 s)*
Response delay t_{on2} (alarm)	0...10 s (0 s)*
Response delay t_{on1} (prewarning)	0...10 s (1 s)*
Delay on release t_{off}	0...99 s (1 s)*
Operating time t_{ae} at $I_{\Delta n} = 1 \times I_{\Delta n1} / 2$ / $I_{\Delta n} = 5 \times I_{\Delta n1} / 2$	≤ 180 ms / ≤ 30 ms
Response time	$t_{an} = t_{ae} + t_{on1} / 2$
Recovery time t_b	≤ 300 ms

Displays, memory

Display range, measured value	0...500 mA
Relative percentage error	0...-35 % / ± 2 digit
Measured-value memory for alarm value	data record measured values
Password	off / 0...999 (off)*
Fault memory behavior	ON / OFF (Latching / Non-latching)

Inputs / outputs

Cable length for external TEST / RESET button	0...32.8 ft (0...10 m)
---	------------------------

Cable lengths for measuring current transformers

Single wire, 6 x AWG 18 (0.75 mm ²)	0...32.8 ft (0...10 m)
Connection	WX series connectors recommended

Switching elements

Number of switching elements	2 SPDT contacts				
Operating principle	normally energized or normally de-energized(*)				
Electrical service life under rated operating conditions	10.000 switching operations				
Contact data acc. to IEC 60947-5-1					
Utilization category	AC-13	AC-14	DC-12	DC-12	DC-12
Rated operational voltage	230 V	230 V	24 V	110 V	220 V
Rated operational current	5 A	3 A	1 A	0,2 A	0.1 A
Minimum contact load	1 mA at AC / DC ≥ 10 V				

Environment / EMC

EMC	IEC 62020				
Operating temperature	-13 °F...+131 °F (-25 °C...+55 °C)				
Climatic class acc. to IEC 60721					
Stationary use (IEC 60721-3-3)	3K5 (except condensation and formation of ice)				
Transport (IEC 60721-3-2)	2K3 (except condensation and formation of ice)				
Long-time storage (IEC 60721-3-1)	1K4 (except condensation and formation of ice)				
Classification of mechanical conditions IEC 60721					
Stationary use (IEC 60721-3-3)					3M4
Transport (IEC 60721-3-2)					2M2
Long-time storage (IEC 60721-3-1)					1M3

Connection

Connection	screw terminals	
rigid / flexible	AWG 24...12 / 24...14	
Multi-conductor connection (2 conductors with the same cross section)		
rigid / flexible	AWG 24...14 / 24...14	
Stripping length	8...9 mm	
Tightening torque	0.5...0.6 Nm	

Other

Operating mode	continuous operation	
Position of normal use	any	
Degree of protection, internal components / terminal (IEC 60529)	IP30 / IP20 (NEMA 1)	
Enclosure material	polycarbonate	
Flammability class	UL94V-0	
DIN rail mounting acc. to	IEC 60715	
Screw mounting	2 x M4 with mounting clip	
Standards	IEC 62020	
Instruction leaflet	TGH1411	
Weight	≤ 150 g	

() * Factory setting

Ordering information: RCMA420 (ordering guide for all models)



Code 2: Auxiliary supply voltage	
Modifier	Supply voltage U_s *
"1"	DC 9.6...94 V / AC 42...460 Hz 16...72 V
"2"	DC 70...300 V / AC 42...460 Hz 70...300 V

* absolute values

Code 1: Contact / analog outputs (optional)		
Modifier	Contact 1	Contact 2
Nothing	Alarm contact	Alarm contact
"M"	All analog outputs*	--
"M1C"	0(4)...20 mA	Alarm contact
"M2C"	0...400 μ A	Alarm contact
"M3C"	0...10 V	Alarm contact

* selectable between 0(4)...20 mA, 0...400 μ A, 0...10 V



North American Headquarters • Coatesville, PA
Toll-Free: 800.356.4266 • Fax: 610.383.7100

Canada • Brampton, ON
Toll-Free: 800-243-2438 • Fax: 905-799-3051

www.bender.org • E-mail: info@bender.org