

A-ISOMETER® IR420-D6

Offline monitor for
de-energized AC, DC and 3(N)AC loads
in TN,TT and IT systems



A-ISOMETER® IR420-D6

Device features

- Insulation monitoring for de-energized TN, TT and unearthed systems AC, 3(N)AC and DC
- Nominal voltage extendable via coupling device
- Two separately adjustable response values 100 kΩ... 10 MΩ
- LEDs: Power On LED, alarm LEDs for insulation faults Alarm 1, Alarm 2
- Combined test/reset button
- Two separate alarm relays with one changeover contact each
- Fault memory behaviour, selectable

Approvals



Product description

The offline monitor of the IR420-D6 series is designed to monitor the insulation resistance of loads in the de-energized state. These loads, usually temporarily operated or de-energized most of the time, e.g. fire extinguisher pumps, slide valve drives etc are supplied from TN, TT or IT systems. During the shut-down periods, however, humidity or other effects may cause insulation faults in the wiring or the loads which may go undetected. Switching the device on may then lead to the tripping of the protective device or may even result in motor fires and the device cannot be operated. In combination with a coupling device, the Isometers can also be used for higher voltages.

Application

- De-energized loads such as automatic fire extinguisher pumps, emergency drives, ship cranes, slide-valve drives in supply lines (gas, water, oil), motor-driven closing systems, diving pumps, drives for anchors, elevators, flue-gas valves and stand-by generators.

Function

When the insulation resistance between the system conductors and earth falls below the set response value, the alarm relays switch and the alarm LEDs light up. The measured value is indicated on the internal LC display. In this way any changes, for example when circuits are connected to the system, can be recognized easily. The fault memory can be reset by pressing the reset button. The test button is used to check the device function. Two separately adjustable response values with one alarm relay each allow prewarning already in case of very high-resistance insulation faults. When the lower response level is reached, an interlocking function will be activated and the connection of a defective load can be prevented.

The insulation resistance is measured via the output L1 or via a contact to the system being monitored. The contact is controlled via the external contact element K3. With the contact in closed position, the system is de-energized and the insulation resistance is being measured.

If the system or load is in operation, K3 opens the contact and insulation monitoring is deactivated. Make sure that the main switch disconnects all poles. To ensure that the measuring voltage can be superimposed onto the system, a low-resistance connection must exist between all line conductors (e.g. by motor windings).

Note: If the IR420-D6 is operated via a coupling device, the auxiliary contact (N/C contact) of K3 between the A-ISOMETER® and the coupling device need not to be designed for the nominal voltage of the system. A rated contact voltage of AC 230 V will be sufficient here.

Measuring principle



Superimposed DC voltage with inverter
(see chapter "Annex" – "Technical aspects...").

Operating elements

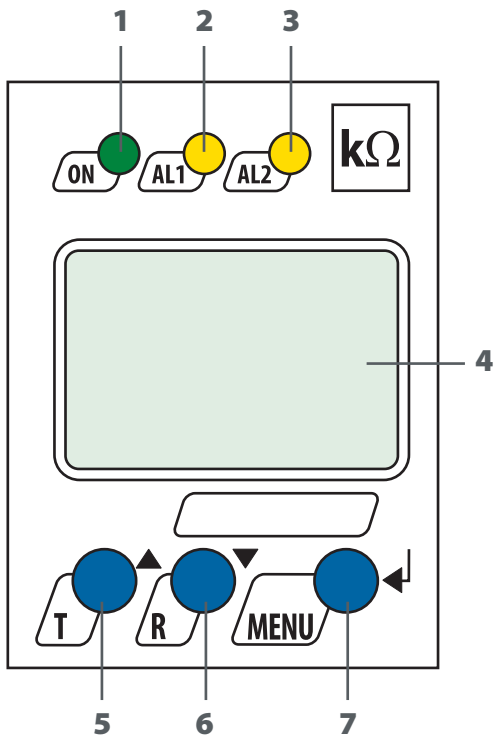

- 1 - Power On LED, flashes in case of interruption of the connecting leads E/KE.
- 2 - Alarm LED "AL1", lights when the value falls below the set response value Alarm 1 and flashes in case of interruption of the connecting leads E/KE.
- 3 - Alarm LED "AL2", lights when the value falls below the set response value Alarm 2 and flashes in case of interruption of the connecting leads E/KE.
- 4 - LC display
- 5 - Test button "T": to call up the self test.
Arrow up key: Parameter change, to move up in the menu.
- 6 - Reset button "R": to delete stored insulation fault alarms
Arrow down key: Parameter change, to move down in the menu.
- 7 - MENU key: to call up the menu system.
Enter key: to confirm parameter change.

Wiring diagrams (examples)

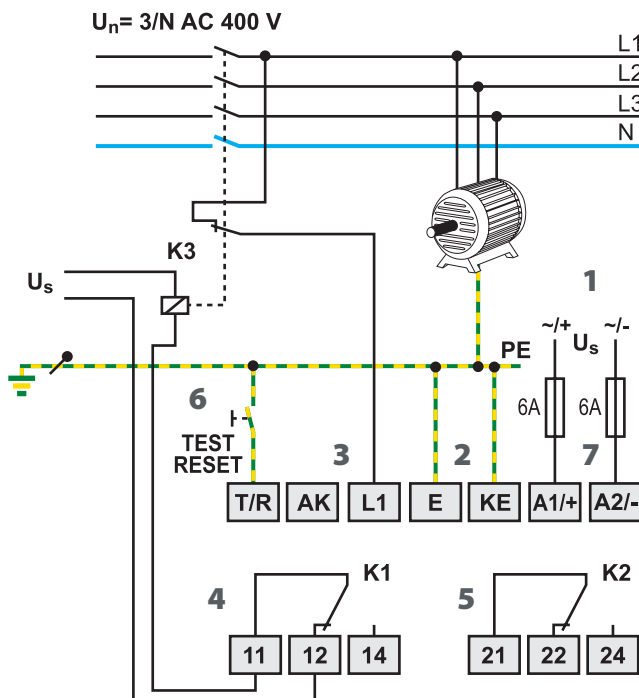

- 1 - Supply voltage U_s (see ordering information) via fuse
- 2 - Separate connection of E, KE to PE
- 3 - Connection to the AC system being monitored:
- 4 - Alarm relay K1: Alarm 1
- 5 - Alarm relay K2: Alarm 2

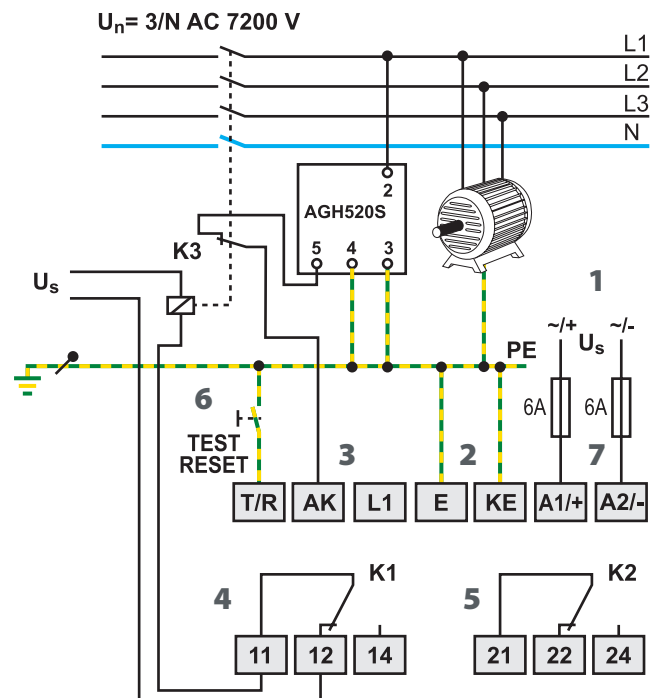

- 6 - Combined test and reset button
short-time pressing (< 1.5 s) = RESET
long-time pressing (> 1.5 s) = TEST
- 7 - Line protection by a fuse in accordance with IEC 60364-4-43 (6 A fuse recommended). In case of supply (A1/A2) from an IT system, both lines have to be protected by a fuse.

1.6

Technical data A-ISOMETER® IR420-D6

Insulation coordination acc. to IEC 60664-1/IEC 60664-3	
Rated insulation voltage	400 V
Rated impulse voltage/pollution degree	4 kV / III
Protective separation (reinforced insulation) between (A1, A2) – (L1, AK, E, KE, T/R) – (11, 12, 14) – (21, 22, 24)	
Voltage test according to IEC 61010-1	2.21 kV
Supply voltage	
Supply voltage U_S	see ordering information
Power consumption	≤ 3 VA
IT system being monitored	
Nominal system voltage U_n	offline
without AGH Nominal contact voltage of the N/C contact of K3 (switch-on contactor) with AGH520S	AC 50...400 Hz, 0...7200 V
Response values	
Response value R_{an1} (Alarm 1)	100 kΩ...10 MΩ (1 MΩ)*
Response value R_{an2} (Alarm 2)	100 kΩ...10 MΩ (100 kΩ)*
Relative percentage error	± 15%
Hysteresis	+ 25%
Specified time	
Response time t_{an} at $R_f = 0.5 \times R_{an}$ and $C_e = 1 \mu F$	≤ 4 s
Start-up delay t	0...10 s (0 s)*
Response delay t_{on}	0...99 s (0 s)*
Measuring circuit	
Measuring voltage U_m	± 12 V
Measuring current I_m (at $R_f = 0 \Omega$)	≤ 10 μA
Internal DC resistance R_i	≥ 1.2 MΩ
Impedance Z_i at 50 Hz	≥ 1,1 MΩ
Permissible extraneous DC voltage U_{fg}	≤ DC 300 V
Permissible system leakage capacitance C_e	≤ 10 μF
Displays, memory	
Display range, measuring value	10 kΩ...20 MΩ
Relative percentage error	± 15%
Password	off / 0...999 (off)*
Fault memory alarm relay	on/off (off)*
Outputs	
Cable length test and reset button	≤ 10 m

Switching elements	
Number of switching elements	2 x 1 changeover contact
Operating principle	N/C or N/O operation (N/O operation)*
Electrical service life, number of cycles	10.000
Contact data acc. to IEC 60947-5-1	
Utilization category	AC-13 AC-14 DC-12 DC-12 DC-12
Rated operational voltage	230 V 230 V 220 V 110 V 24 V
Rated operational current	5 A 3 A 0.1 A 0.2 A 1 A
Minimum current	1 mA at AC/DC > 10 V
Environment/EMC	
EMC	IEC 61326
Operating temperature	- 25 °C...+ 55 °C
Climatic class acc. to IEC 60721	
Stationary use (IEC 60721-3-3)	3K5 (except condensation and formation of ice)
Transport (IEC 60721-3-2)	2K3 (except condensation and formation of ice)
Long-time storage (IEC 60721-3-1)	1K4 (except condensation and formation of ice)
Classification of mechanical conditions IEC 60721	
Stationary use (IEC 60721-3-3)	3M4
Transport (IEC 60721-3-2)	2M2
Long-time storage (IEC 60721-3-1)	1M3

Connection	
Connection	screw-type terminals
rigid/flexible/conductor sizes	0.2...4/0.2...2.5 mm ² /24-12 AWG
Multi-conductor connection (2 conductors with the same cross section)	
rigid/flexible	0.2...1.5/0.2...1.5 mm ²
Stripping length	8 mm
Tightening torque	0.5...0.6 Nm

General data	
Operating mode	continuous operation
Mounting	any position
Degree of protection, internal components (IEC 60529)	IP30
Degree of protection, terminals (IEC 60529)	IP20
Enclosure material	polycarbonate
DIN rail mounting acc. to	IEC 60715
Screw mounting	2 x M4 with mounting clip
Product standards	DIN EN 61557-8: 1998-05 EN 61557-8: 1997-03, IEC 61557-8: 1997-02, ASTM F1134-94
Operating manual	BP101014
Weight	≤ 150 g

()* = factory setting

Ordering information

Type	Supply voltage* U_S	Response value R_{an}	System leakage capacitance C_e	Art. No.
IR420-D6-1	DC 9.6...94 V/AC 42...460 Hz 16...72 V	100 kΩ...10 MΩ	≤ 10 μF	B 9101 6415
IR420-D6-2	DC 70...300 V/AC 42...460 Hz 70...300 V	100 kΩ...10 MΩ	≤ 10 μF	B 9101 6407

* absolute values

Accessories

Type	Nominal system voltage* U_n	Art. No.
AGH520S	AC 50...400 Hz 0...7200 V	B 913 033

Type	Art. No.
Mounting clip for screw mounting (one piece per device)	B 9806 0008

Dimension diagram XM420

Dimensions in mm

Open the front plate cover in direction of arrow!

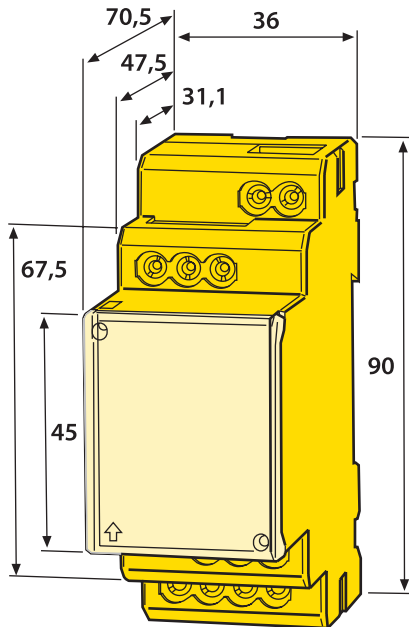

Screw mounting

Note: The upper mounting clip must be ordered separately (see ordering information)!

