

A-ISOMETER® IR420

Electrical safety for unearthed AC control circuits (IT systems)



A-ISOMETER® IR420

Device features

- Insulation monitoring for IT control circuits AC 0...300 V
- Two separately adjustable response values
- Preset function (automatic assignment of basic parameters)
- Connection monitoring system/earth
- LEDs: Power On, Alarm 1, Alarm 2
- Internal/external test/reset button
- Two separate alarm relays (one changeover contact each)
- N/O or N/C operation, selectable
- Fault memory behaviour, selectable
- Self monitoring with automatic alarm message
- Multi-functional LC display
- Adjustable response delay
- Two-module enclosure (36 mm)
- RoHS-compliant

Approvals



Product description

The A-ISOMETER® of the IR420 series is designed to monitor the insulation resistance of AC control circuits (IT systems) 0...300 V. If the systems to be monitored include DC components, such as switched-mode power supplies or solenoid valves, the display and operating characteristics may be affected.

The display and response values apply to pure AC systems.

An external supply voltage allows de-energized systems to be monitored too.

Application

- AC control circuits in the industrial sector, mechanical engineering, power plants, elevators, automation systems etc.
- AC control and auxiliary circuits in accordance with IEC 60204-1/DIN EN 60204-1 Electrical equipment of machines
- AC auxiliary circuits in accordance with DIN VDE 0100-725 (VDE 0100-725)
- Smaller AC IT systems such as lighting systems, mobile generators

Function

The currently measured insulation resistance is indicated on the LC display. In this way any changes, for example when circuits are connected to the system, can be recognized easily. When the value falls below the preset response values, the response delay "t_{on}" starts. Once the response delay "ton" has elapsed, the "K1/K2" alarm relays switch and the alarm LEDs "AL1/AL2" light up. Two separately adjustable response values/alarm relays allow a distinction to be made between "prewarning" and "alarm". If the insulation resistance exceeds the release value (response value plus hysteresis), the alarm relays return to their initial position. If the fault memory is enabled, the alarm relays remain in the alarm state until the reset button is pressed or until the supply voltage is switched off. The test button is used to check the device function. The parameterization of the device can be carried out via the LC display or the function keys integrated in the front plate.

Connection monitoring

The connections to the system (L1 / L2) and earth (E / KE) are either automatically checked every 24 h, or by pressing the test button or when supply voltage has been connected. In case of interruption of a connecting lead, the alarm relays K1 / K2 switch, the LEDs ON // AL1 // AL2 flash and the following message appears on the display:

"E.02" indicating a fault in the connecting leads to the system,

"E.01" indicating a fault in the connecting leads to PE.

After eliminating the fault, the alarm relays return to their initial position either automatically or by pressing the reset button.

Preset function

After connecting the device for the first time, the nominal system voltage is measured and the response values are set automatically.

Measuring principle

The A-ISOMETER® IR420 uses the measuring principle "superimposed DC voltage".

Operating elements

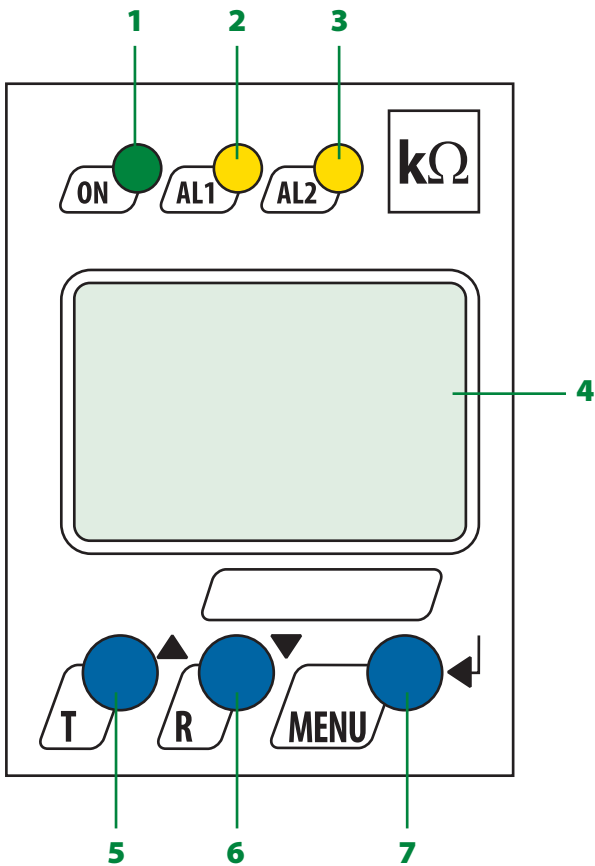

- 1 - Power "ON" LED, flashes in case of interruption of the connecting leads earth/ KE or L1 / L2.
- 2 - Alarm LED "AL1", lights when the value falls below the set response value Alarm 1 and flashes in case of interruption of the connecting leads earth/KE or L1/L2).
- 3 - Alarm LED "AL2", lights when the value falls below the set response value Alarm 2 and flashes in case of interruption of the connecting leads earth/KE or L1/L2).
- 4 - LC display
- 5 - Test button "T": To call up the self test.
Arrow up key: Parameter change, to move up in the menu.
- 6 - Reset button "R": To delete stored insulation fault alarms
Arrow down key: Parameter change, to move down in the menu.
- 7 - MENU key: To call up the menu system.
Enter key: To confirm parameter change.

Wiring diagram

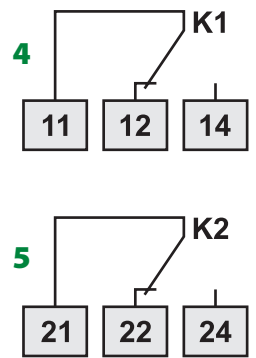
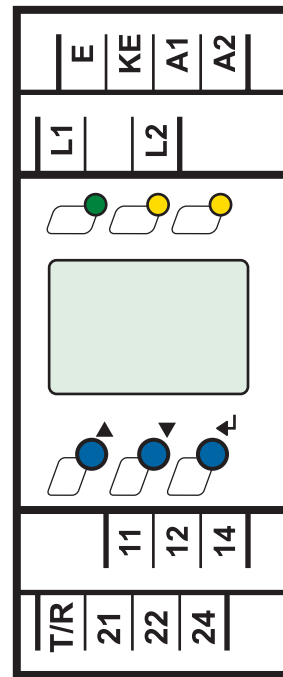
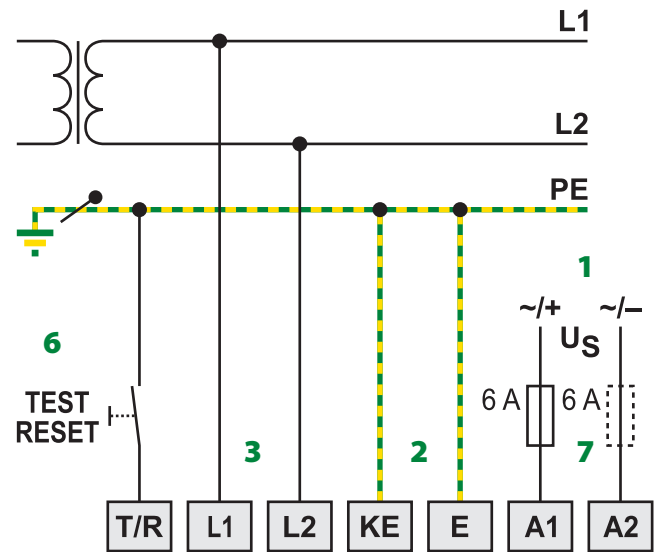

- 1 - Supply voltage U_S (see ordering information) via fuse
- 2 - Separate connection of E, KE to PE
- 3 - Connection to the AC system to be monitored:
AC: Connect terminals L1, L2 to conductor L1, L2.
- 4 - Alarm relay K1: Alarm 1
- 5 - Alarm relay K2: Alarm 2
- 6 - Combined test and reset button
short-time pressing (< 1.5 s) = RESET
long-time pressing (> 1.5 s) = TEST
- 7 - Line protection by a fuse in accordance with IEC 60364-4-43 (6 A fuse recommended). In case of supply (A1/A2) from an IT system, both lines have to be protected by a fuse.

1:1

Technical data A-ISOMETER® IR420

Insulation coordination acc. to IEC 60664-1/IEC 60664-3	
Rated insulation voltage	250 V
Rated impulse voltage/pollution degree	2.5 kV / III
Protective separation (reinforced insulation) between (A1, A2) - (L1, L2, E, KE, T/R) - (11, 12, 14) - (21, 22, 24)	
Voltage test according to IEC 61010-1	2.21 kV
Supply voltage	
Supply voltage U_s	see ordering information
Power consumption	≤ 3 VA
IT system being monitored	
Nominal system voltage U_n	AC 0...300 V
Rated frequency f_n	42...460 Hz
Response values	
Response value R_{an1} (Alarm 1)	1...200 k Ω
Response value R_{an2} (Alarm 2)	1...200 k Ω
Preset mode	$U_n \leq 72$ V R_{an1} (Alarm 1) = 20 k Ω / R_{an2} (Alarm 2) = 10 k Ω $U_n > 72$ V R_{an1} (Alarm 1) = 46 k Ω / R_{an2} (Alarm 2) = 23 k Ω
Operating error 1 k Ω ...5 k Ω /5 k Ω ...200 k Ω	± 0.5 k Ω / $\pm 15\%$
Hysteresis	25%
Specified time	
Response time t_{an} at $R_f = 0.5 \times R_{an}$ and $C_e = 1$ μ F	≤ 1 s
Start-up delay t	0...10 s (0 s)*
Response delay t_{on}	0...99 s (0 s)*
Measuring circuit	
Measuring voltage U_m	12 V
Measuring current I_m (at $R_f = 0$ Ω)	≤ 200 μ A
Internal DC resistance R_i	≥ 62 k Ω
Impedance Z_i at 50 Hz	≥ 60 k Ω
Permissible extraneous DC voltage U_{fg}	\leq DC 300 V
Permissible system leakage capacitance C_e	≤ 20 μ F
Displays, memory	
Display range, measuring value	1 k Ω ...1 M Ω
Operating error 1 k Ω ...5 k Ω /5 k Ω ...1 M Ω	± 0.5 k Ω / $\pm 15\%$
Password	off / 0...999 (off)*
Fault memory, alarm relay	on/off*
Outputs	
Cable length test and reset button	≤ 10 m
Switching elements	
Number of switching elements	2 x 1 changeover contact
Operating principle	N/C or N/O operation (N/O operation)*
Electrical service life	10.000 switching operations
Contact data acc. to IEC 60947-5-1	
Utilization category	AC-13 AC-14 DC-12 DC-12 DC-12
Rated operational voltage	230 V 230 V 220 V 110 V 24 V
Rated operational current	5 A 3 A 0.1 A 0.2 A 1 A
Minimum current	1 mA at AC/DC ≥ 10 V
Environment/EMC	
EMC	IEC 61326
Operating temperature	-25 °C...+55 °C
Climatic class acc. to IEC 60721	
Stationary use (IEC 60721-3-3)	3K5 (except condensation and formation of ice)
Transport (IEC 60721-3-2)	2K3 (except condensation and formation of ice)
Long-time storage (IEC 60721-3-1)	1K4 (except condensation and formation of ice)
Classification of mechanical conditions IEC 60721	
Stationary use (IEC 60721-3-3)	3M4
Transport (IEC 60721-3-2)	2M2
Long-time storage (IEC 60721-3-1)	1M3
Connection	
Connection	screw-type terminals
rigid/flexible/conductor sizes	0.2...4/0.2...2.5 mm ² /24-12 AWG
Multi-conductor connection (2 conductors with the same cross section)	
rigid/flexible	0.2...1.5/0.2...1.5 mm ²
Stripping length	8...9 mm
Tightening torque	0.5...0.6 Nm
Other	
Operating mode	continuous operation
Mounting	any position
Degree of protection, internal components (IEC 60529)	IP30
Degree of protection, terminals (IEC 60529)	IP20
Enclosure material	polycarbonate
DIN rail mounting acc. to	IEC 60715
Screw mounting	2 x M4 with mounting clip
Product standards	DIN EN 61557-8: 1998-05, EN 61557-8: 1997-03, IEC 61557-8: 1997-02, ASTM F 1207M-96 (2002)
Operating manual	BP101012
Weight	≤ 150 g

* = factory setting

Ordering information

Typ	Nominal system voltage* U_n	Supply voltage* U_s	Response value R_{an}	System leakage capacitance C_e	Art. No.
IR420-D4-1	AC 42...460 Hz 0...300 V	DC 9,6...94 V/AC 42...460 Hz 16...72 V	1...200 k Ω	< 20 μ F	B 9101 6409
IR420-D4-2	AC 42...460 Hz 0...300 V	DC 70...300 V/AC 42...460 Hz 70...300 V	1...200 k Ω	< 20 μ F	B 9101 6405

* absolute values

Accessories

Type	Art. No.
Mounting clip for screw mounting (one piece per device)	B 9806 0008

Dimension diagram XM420

Dimensions in mm

Open the front plate cover in direction of arrow!

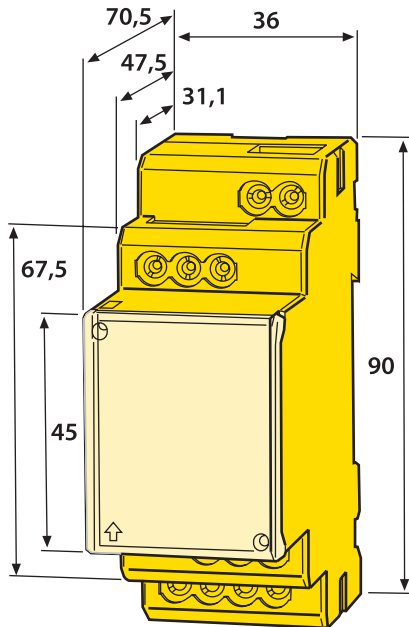

Screw mounting

Note: The upper mounting clip must be ordered separately (see ordering information)!

