

Loop monitor GM420

Relay designed to monitor loop resistances or
PE conductor connections



GM420

Device features

- Loop monitoring of the PE conductor in AC systems
- Measuring circuit providing a high resistance against extraneous voltages and indication of extraneous voltages
- Adjustable start-up delay, response delay and delay on release
- Adjustable switching hysteresis
- Digital measured value display via multi-functional LC display
- Preset function (automatic assignment of basic parameters)
- LEDs: Power On, Alarm 1, Alarm 2
- Measured value memory for operating value
- Continuous self monitoring
- Internal test/reset button
- Two separate alarm relays with one changeover contact each
- N/C or N/O operation and fault memory behaviour selectable
- Password protection for device setting
- Sealable transparent cover
- Two-module enclosure (36 mm)
- RoHS-compliant

Product description

The loop monitor of the GM420 series is designed to monitor the resistance of PE conductor connections in AC systems and in de-energized systems. For the measurement of the resistance the extraneous voltage U_f between the terminals E and KE must not exceed AC 12 V. At voltages above AC 12 V only the voltage is measured. The ohmic resistance of the conductor loop and the existing extraneous AC voltage U_f will be indicated on the display. The currently measured value is continuously indicated on the LC display. If the measured resistance value increases above the set response value, the alarm will be activated and stored. Adjustable time delays allow installation-specific requirements to be considered.

Typical applications

- Loop monitoring of motors
- Loop monitoring of PE conductor connections for wire interruptions in electrical installations
- Monitoring of earthing systems

Function

Once the supply voltage is applied, the starting delay „t“ is activated. Values of the resistance and extraneous voltage changing during this time do not influence the switching state of the alarm relays. The devices provide two individually adjustable measuring channels (loop resistance / extraneous voltage U_f). When the measuring value exceeds the response value $> R$ (Alarm 1) or $> U_f$ (Alarm 2), the time of the response delay $t_{on1/2}$ begins. Once the response delay has elapsed, the alarm relays switch and the alarm LEDs light. If the measuring quantity falls below the release value (response value plus hysteresis) after the alarm relays have switched, the selected release delay „t_{off}“ begins. When „t_{off}“ has elapsed, the alarm relays switch back to their initial position. When the fault memory is activated, the alarm relays remain in the alarm state until the reset button R is pressed.

Preset function

After connecting the device to the supply voltage for the first time, the response value for the loop resistance (Alarm 1) is automatically set once only to the following value:

Response value loop resistance ($> R$) = $(R_{mess} + 0.5 \Omega) \times 1.5$.

If the measured resistance value is $> 66 \Omega$, the response value will automatically be set to 100Ω . After restoring the factory settings, the preset function is automatically active again.

Dimension diagram XM420

(dimensions in mm)

Open the front plate cover in direction of arrow!

Screw fixing

Note: The upper mounting clip must be ordered separately (see ordering information).

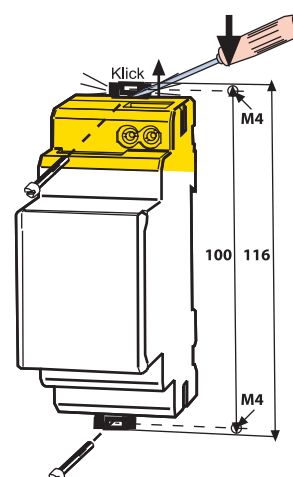
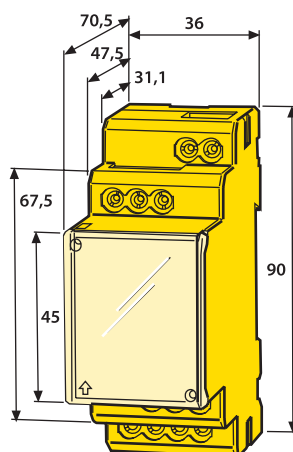

Operating elements

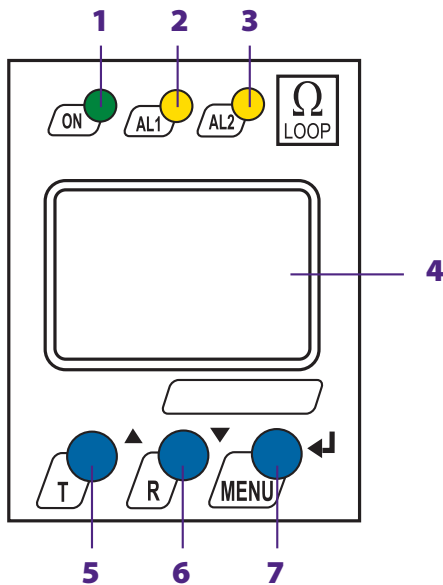

- 1 - Power On LED „ON“ (green), lights when the supply voltage is applied and flashes in the event of system fault alarm.
- 2 - Alarm LED „AL1“ (yellow), lights when the response value has been exceeded > R and flashes in the event of system fault alarm.
- 3 - Alarm LED „AL2“ (yellow), lights when > U_f has been exceeded and flashes in the event of system fault alarm.
- 4 - Multi-functional LC display.
- 5 - Test button „T“: to call up the self test: Press the key > 1.5 s.
UP key: Parameter change, to move up in the menu.
- 6 - Reset button „R“: to delete stored insulation fault alarms: press the key > 1.5 s.
DOWN key: Parameter change, to move down in the menu.
- 7 - MENU key: To call up the menu system: press the key > 1.5 seconds.
Enter key: to confirm parameter change.
Press the ESC key > 1.5 s: to abort an action or to return to the previous menu level.

Wiring diagram

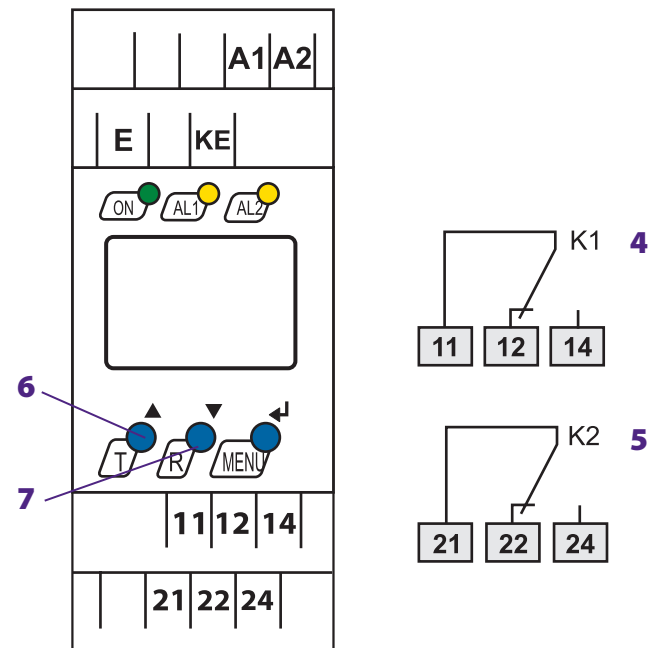
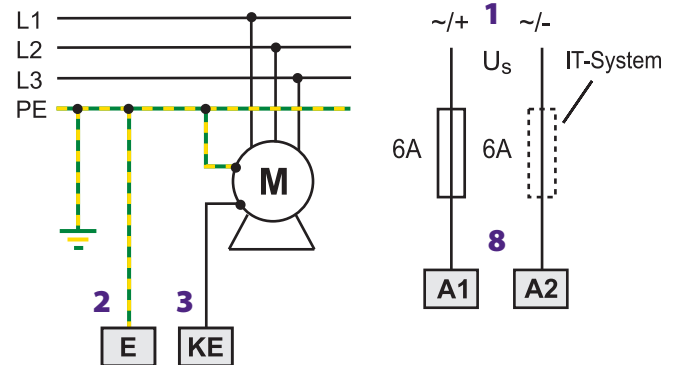

- 1 - Supply voltage U_S (see ordering details) via fuse
- 2 - Connection of E to the PE conductor
- 3 - Connection of KE to the loads or the monitoring conductor
- 4 - Alarm relay K1: Alarm 1 programmable: ERROR, > R, OL, > U_f, TEST
- 5 - Alarm relay K2: Alarm 2 programmable: ERROR, > R, OL, > U_f, TEST
- 6 - Test button „T“
- 7 - Reset button „R“
- 8 - Line protection by a fuse in accordance with IEC 60364-4-43 (6 A fuse recommended). In case of supply (A1/A2) from an IT system, both lines have to be protected by a fuse.

Ordering information

Device type	Measuring range Loop resistance	Measuring range Interference voltage	Supply voltage U _S	Art. No.
GM420-D-1	0...100 Ω	AC 0...50 V	DC 9.6V...94 V / AC 15...460 Hz, 16...72 V	B 9308 2001
GM420-D-2	0...100 Ω	AC 0...50 V	DC 70...300 V / AC 15...460 Hz, 70...300 V	B 9308 2002
Mounting clip for screw fixing (1 piece per device, accessories)				B 9806 0008

Technical data loop monitoring relay GM420

Insulation coordination acc. to IEC 60664-1 / IEC 60664-3	
Rated voltage	400 V
Rated impulse voltage/pollution degree	4 kV / III
Protective separation (reinforced insulation) between: (A1, A2) - (E, KE) - (11-12-14) - (21-22-24)	
Voltage test acc. to IEC 61010-1:	
(E, KE) - [(A1-A2), (11-12-14)]	3.32 kV
(E, KE) - (21-22-24)	2.21 kV
(A1- A2) - (11-12-14) - (21-22-24)	2.21 kV
Supply voltage	
Supply voltage U_s	see ordering information
Frequency range U_s	see ordering information
Power consumption	≤ 3.5 VA
Measuring circuit	
Loop resistance R_m:	
Measuring range R_m	0...100 Ω
Measuring current I_m	DC 20 mA
Measuring voltage U_m	\leq DC 24 V
Extraneous voltage U_f:	
Measuring range U_f	AC 0...50 V
Rated frequency f_n	42...460 Hz
Disconnection of the measuring loop at U_f	≥ 12 V
Reclosing of the measuring loop	≤ 10 V
Extraneous voltage U_f	≤ 440 V
Permissible extraneous DC voltage without influence on the measurement	DC 0 V
Response values	
Loop resistance $> R$ (Alarm 1)	0.1...100 Ω
Resolution of setting $R = 0...10$ Ω	0.1 Ω
Resolution of setting $R = 10...100$ Ω	1 Ω
Preset function:	
Loop resistance ($> R$) =	$(R_m + 0.5 \Omega) \times 1.5$ *
Relative percentage error 0...1 Ω	$\pm 20\%$, ± 1 digit
Relative percentage error 1...100 Ω	$\pm 5\%$, ± 1 digit
Hysteresis $> R$	1...40 % (25 %)*
Extraneous voltage $> U$ (Alarm 2)	1...50 V (25 V)*
Resolution of setting U_f 1...50 V	0.5 V
Relative percentage error U_f ($> U$) in the range 50/60 Hz	$\pm 2\%$, ± 1 digit
Relative percentage error U_f ($> U$) in the range 42...460 Hz	$\pm 10\%$, ± 1 digit
Hysteresis $> U$	1...40 % (5 %)*
Specified time	
Start-up delay t	0...99 s (0 s)*
Response delay $t_{on1/2}$	0...99 s (0 s)*
Delay on release t_{off}	0...99 s (0.5 s)*
Operating time	
in case of open loop connection ($R > 50$ k Ω) t_{ae}	≤ 40 ms
in case of closed loop connection ($> R$) t_{ae}	≤ 500 ms
in case of extraneous voltage ($> U$) and overload (OL) t_{ae}	≤ 100 ms
Response time t_{an}	$t_{an} = t_{ae} + t_{on1/2}$
Recovery time t_b	≤ 300 ms
Recovery time t_b after disconnection for safety reasons	≤ 1 s

Displays, memory

Displays	LC display, multifunctional, not illuminated
Display range, measuring value R_m	0...100 Ω
Display range, measuring value U_f	AC 0...50 V
Relative percentage error, loop resistance 0...1 Ω	$\pm 20\%$, ± 1 digit
Relative percentage error, loop resistance 1...100 Ω	$\pm 5\%$, ± 1 digit
Relative percentage error, voltage in the range 50/60 Hz	$\pm 2\%$, ± 1 digit
Relative percentage error, voltage in the range 42...460 Hz	$\pm 10\%$, ± 1 digit
History memory (HiS) for the first alarm value	data record measured values
Password	off / 0...999 (OFF)*
Fault memory (M) alarm relay	on / off (on)*

Switching elements

Number of switching elements	2 x 1 changeover contacts (K1, K2)
Operating principle	N/C operation / N/O operation
	K1: Err, $> R$, OL, $> U$, tES (device error, loop resistance)
	Measuring current disconnection: N/O operation n.o.)*
	K2: Err, $> R$, OL, $> U$, tES (overvoltage: N/O operation n.o.)*
Electrical service life, number of cycles	10000
Contact data acc. to IEC 60947-5-1	
Utilization category	AC13 AC14 DC-12 DC-12 DC-12
Rated operational voltage	230 V 230 V 24 V 110 V 220 V
Rated operational current	5 A 3 A 1 A 0.2 A 0.1 A
Minimum contact load	1 mA at AC/DC ≥ 10 V

Environment / EMC

EMC	IEC 61326
Operating temperature	-25 °C...+55 °C
Classification of climatic conditions IEC 60721	
Stationary use (IEC 60721-3-3)	3K5 (except condensation and formation of ice)
Transport (IEC 60721-3-2)	2K3 (except condensation and formation of ice)
Long-time storage (IEC 60721-3-1)	1K4 (except condensation and formation of ice)
Classification of mechanical conditions acc. to IEC 60721:	
Stationary use (IEC 60721-3-3)	3M4
Transport (IEC 60721-3-2)	2M2
Long-time storage (IEC 60721-3-1)	1M3

Connection

Connection type	screw terminals
Connection properties	
rigid / flexible / conductor sizes	0.2...4 / 0.2...2.5 mm ² / AWG 24...12
Multi-conductor connection (two conductors with the same cross section)	
rigid / flexible	0.2...1.5 mm ² / 0.2...1.5 mm ²
Stripping length	8...9 mm
Tightening torque	0.5...0.6 Nm

Other

Mode of operation	Continuous operation
Mounting	any position
Degree of protection, internal components (IEC 60529)	IP30
Degree of protection, terminals (IEC 60529)	IP20
Enclosure material	polycarbonat
Flammability class	UL94 V-0
DIN rail mounting	IEC 60715
Screw mounting	2 x M4 with mounting clip
Software version	D268 V1.0x
Weight	≤ 150 g

()* = factory setting