

Protocol converter FTC470XET

Protocol converter to interface the BMS bus with TCP/IP via Ethernet

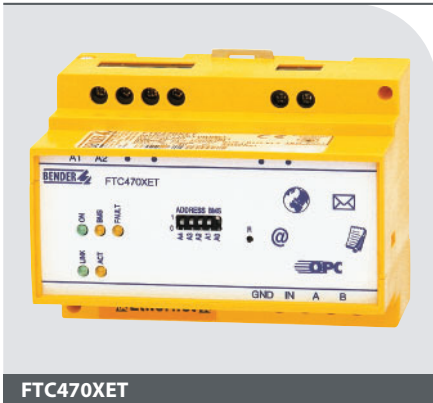

FTC470XET

Device features

- Display of BMS data via standard web browser
- Fast and easy parameterization of BENDER systems from a central point
- Display of current operating and alarm messages and measured values
- Detailed information at a glance
- Display of historical data
- Useful data logger function
- OPC interface for communication with higher-level systems (building management systems or visualization software)
- Easy installation and commissioning
- E-mail notification in case of alarm and system faults
- Remote maintenance and remote diagnosis per LAN, WAN or Internet
- Independent of hard and software

Product description

The protocol converter FTC470XET is designed to be used as Ethernet gateway with web server. It converts data from the BMS bus into TCP/IP protocol (Ethernet). In this way, data from BMS systems can be displayed on a personal computer via a web browser. Additional software need not to be installed.

Application

- Conversion of BMS data into TCP/IP protocol (Ethernet)
- Setting, observing and analysing of BENDER products with communication capabilities, such as RCMS, EDS and MEDICS® systems.
- Data transmission to building services management systems and visualization systems via an integrated OPC interface.

Function

The protocol converter FTC470XET can be integrated into existing EDP systems like a personal computer. After entering an IP address and connection to the network and to a BMS system, a standard web browser (e.g. Internet Explorer, Netscape Navigator) of a personal computer allows access to the entire data of a BMS system. In this way, all important measuring data of the system are directly available. The parameterization of the BENDER systems is protected by a password.

Approvals



Operating elements

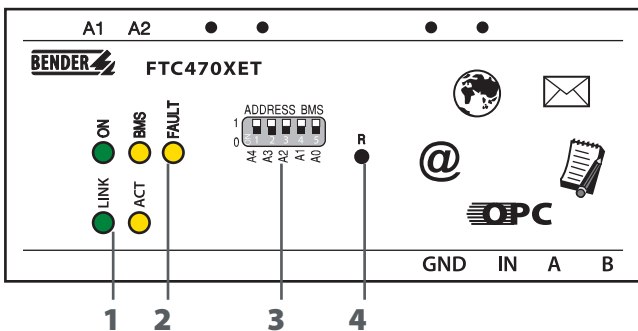

- 1 - Ethernet status indication
- 2 - BMS bus status indication
- 3 - DIP switches for binary BMS bus address setting: 1...30
- 4 - Reset button "R"

Wiring diagram

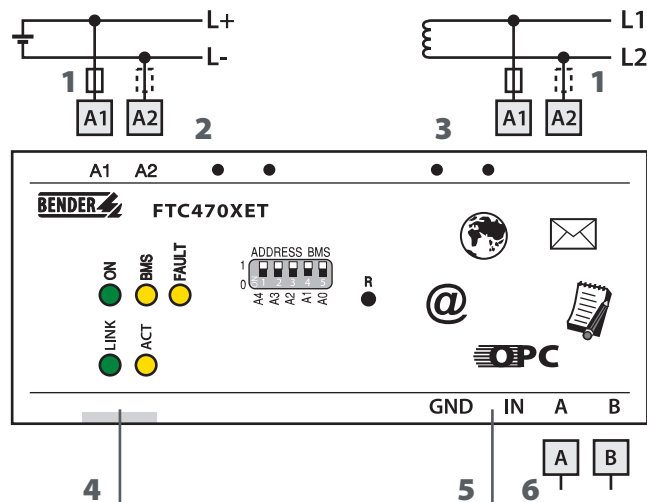

- 1 - U_S see ordering information, 6 A fuse recommended
- 2 - System $U_S = DC 85...276 V$
- 3 - System $U_S = AC 85...276 V$
- 4 - Ethernet connection RJ45
- 5 - Digital input to restore factory settings
- 6 - BMS bus connection

1.8.3

Technical data protocol converter FTC470XET

Insulation coordination acc. to IEC 60664-1	
Rated insulation voltage	AC 250 V
Rated impulse voltage/pollution degree	4 kV/3
Supply voltage	
Supply voltage U_S	see ordering information
Frequency range of U_S	DC, 50...400 Hz
Power consumption	≤ 12 VA
Interfaces	
BMS	
Interface/protocol	RS-485/BMS (internal)
Baud rate	9.6 kBit/s
Cable length	≤ 1200 m
Recommended cable (shielded, shield connected to PE on one side)	J-Y(ST)Y min. 2 x 0.6
Mode	Master/Slave
Connection	terminals A/B
Terminating resistor	120 Ω (0.25 W)
Device address, BMS bus	DIP switch 1...30
Alarm LEDs	ON/FAULT/BMS
Factory setting, device address	1
Ethernet	
Interface/protocol	Ethernet 10-base-T/TCP/IP
Connection	RJ45
Baud rate	10 Mbit/s
Alarm LEDs	Link/Act
General data	
EMC immunity	acc. to EN 61000-6-2
EMC emission	acc. to EN 61000-6-4
Classification of climatic conditions acc. to IEC 60721	
Stationary use	3K5
Transport	2K3
Long-time storage	1K4
Operating temperature	-10 °C...+55 °C
Classification of mechanical conditions acc. to IEC 60721	
Stationary use	3M4
Transport	2M2
Long-time storage	1M3
Operating mode	continuous operation
Mounting	any position
Connection	screw-type terminals
Connection properties	
rigid/flexible/conductor sizes	0.2...4/0.2...2.5 mm ² /AWG 22-12
flexible with ferrule, without/with plastic sleeve	0.25...2 mm ²
Stripping length	8 mm
Tightening torque	0.5 Nm
Degree of protection, internal components (IEC 60529)	IP30
Degree of protection, terminals (IEC 60529)	IP20
Type of enclosure/dimension diagram	X470
Screw mounting	2 x M4
DIN rail mounting acc. to	DIN EN 60715/IEC 60715
Flammability class	UL94V-0
Operating Manual	TGH1375
Weight	≤ 400 g

Ordering information

Type	Supply voltage U_S	Art. No.
FTC470XET	AC/DC 85...276 V*	B 9506 1001

*Absolute value

Dimension diagram X470

Dimensions are given in mm

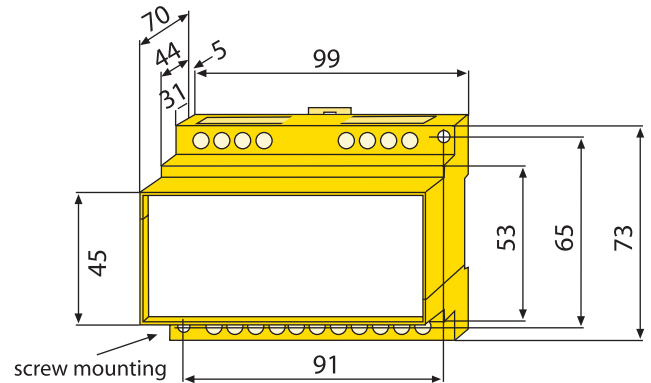

Visualization of BMS data

FTC470XET display: currently measured values of a BMS device

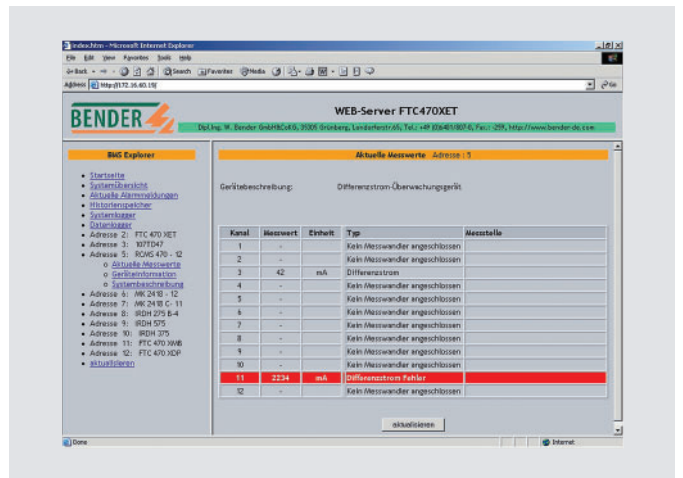

FTC470XET display: E-mail function setting

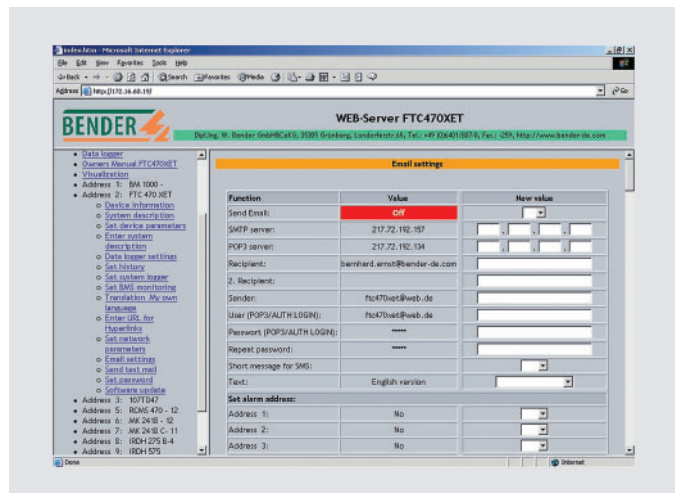

1.8.3