

# Protocol converter FTC470XDP

Protocol converter to interface the BMS bus with the PROFIBUS DP



FTC470XDP

### Product description

The protocol converter FTC470XDP is designed to transmit data from the BMS bus to the PROFIBUS DP and vice versa. In this way, information from communication-capable BENDER products, such as EDS, RCMS or MEDICS® systems can be integrated into a PROFIBUS DP system. Programming or adaptations on the PROFIBUS DP side have to be carried out by the user.

### Application

- Converting BMS data into PROFIBUS DP data
- Setting, observing and analysing of communication-capable BENDER products, such as RCMS, EDS and MEDICS® systems.
- Transmitting all BMS data to PROFIBUS DP
- Displaying BENDER data on PROFIBUS-compatible software
- Reactions on the PROFIBUS side to BMS events
- Connection to PROFIBUS-compatible building services management systems
- Reactions on the BMS side to events on the PROFIBUS DP side

### Function

The protocol converter FTC470XDP is incorporated into the PROFIBUS DP system as a slave and into a BMS system either as a master or a slave. The PROFIBUS DP master, e.g. a personal computer utilizing a PROFIBUS card or a PLC must be programmed in a way that the protocol converter is capable of triggering the respective requests and getting replies. For appropriate programming, the user is required to have a thorough PROFIBUS DP knowledge. The necessary documentation together with the entire command syntax is a component of the FTC470XDP manual.

### Approvals



### Operating elements

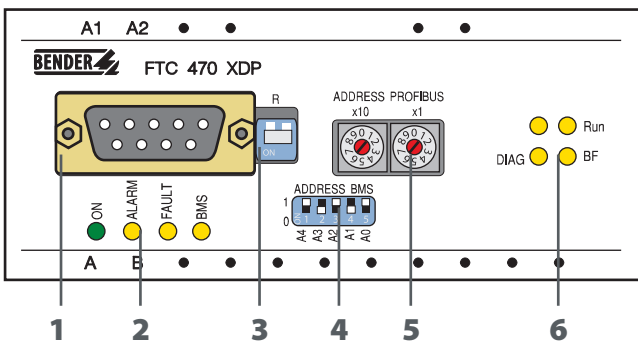

- 1 - Socket for PROFIBUS cable: 9-pin SUB-D
- 2 - BMS bus status indication
- 3 - Micro switch for PROFIBUS DP termination: "ON" = terminating resistor activated
- 4 - Switch for BMS bus address setting: Switch for BMS bus address setting 1...30
- 5 - Rotary switch for PROFIBUS DP address setting: 1...99
- 6 - PROFIBUS DP status indication

### Wiring diagram

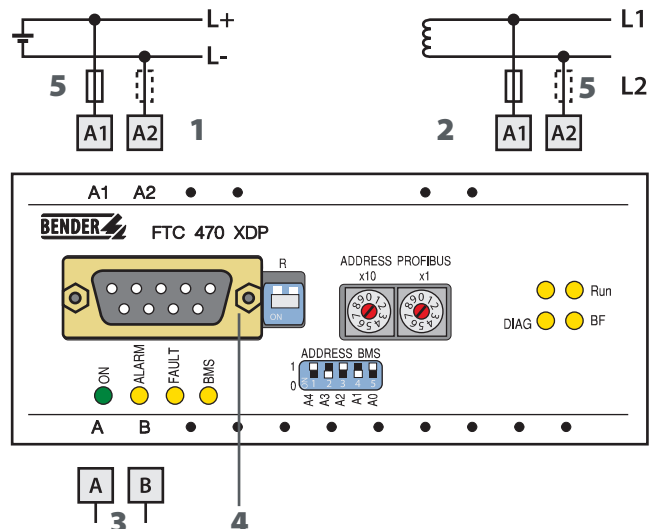

- 1 - System connection  $U_S = DC 85...276 V$
- 2 - System connection  $U_S = AC 85...276 V$
- 3 - BMS bus connection
- 4 - PROFIBUS DP 9-pin SUB-D
- 5 -  $U_S$ , see ordering information, 6 A fuse recommended)

