

Insulation fault evaluators

EDS460/490 – EDS461/491

Insulation fault evaluators with display and control function for EDS systems



Insulation fault evaluators
EDS460/490 – EDS461/491

Device features

- Insulation fault location and residual current measurement
- For AC, 3AC, DC and IT systems
- Control and display function within one device (EDS...D)
- 12 measuring channels (circuits) for measuring current transformers of the W, WR, WS series
- Up to 90 EDS evaluators in one system (1080 measuring channels)
- Scanning time for all measuring channels 10 s
- Response sensitivity
EDS460/490 2...10 mA (100 Ω/V)
EDS461/491 0.2...1 mA (1000 Ω/V)
- History memory to store 300 events
- Two alarm relays with one changeover contact each
- N/O or N/C operation, selectable
- Connection external reset/test button
- Indication via graphical display resp. 7-segment display and alarm LEDs
- BMS address range 1...90
- Serial RS-485 interface
- Continuous CT connection monitoring
- Fault memory behaviour selectable
- Device version EDS490/491 with one alarm contactor per channel
- Additional residual current measurement

Product description

The insulation fault evaluator of the EDS460/490 series in combination with the A-ISOMETER® IRDH575 or the insulation fault test device PGH is designed to localize insulation faults in unearthed power supplies (IT systems). The test current signals generated by the insulation monitoring device IRDH575 or the insulation fault test device PGH are scanned by measuring current transformers and evaluated by the insulation fault evaluators. Up to 12 measuring current transformers can be connected to one EDS. A total of 90 EDS evaluators can be connected via one RS-485 interface (BMS protocol). Hence, up to 1080 circuits can be monitored. The maximum scanning time is approx. 4...10 s, see TGH1394.

Application

- Insulation fault location in AC, AC / DC and DC IT systems
- Main and control circuits in industrial installations and ships
- Diode-decoupled DC IT systems in power stations
- Systems for medical locations

Function

Insulation fault location is started via the A-ISOMETER IRDH575 or the PGH. Once started, the insulation fault evaluator EDS simultaneously scans all measuring current transformers (channels). If several EDS exist, these devices are also scanned simultaneously.

When the test current generated by a measuring current transformer exceeds the set response value, the alarm LED 2 lights up, the common alarm relay switches and the faulty circuit is indicated as plain text on the graphical display. Version EDS...L indicates faulty outgoing circuits via alarm LEDs. The connection between the measuring current transformer and the insulation fault evaluator is continuously monitored. In the event of wire interruption, the alarm LED 1 lights up and the alarm relay switches.

With the fault memory activated, the alarm messages of the individual channels remains stored until the reset button is pressed or until a reset command is given via the RS-485 interface. When the fault memory is deactivated, the alarm message remains stored until the insulation fault is eliminated.

History memory in EDS460/461-D/EDS490/491-D

The device utilizes a history memory for failsafe storing of up to 300 measured values/ events (date, time, channel, event code, measured value), so that all data about an outgoing circuit or an area can be traced back at any time (what happened when).

Residual current measurement

EDS evaluators can also be used to detect residual currents in unearthed power supplies (IT systems). This is essential when also AC residual currents are to be localized in the circuits.

Device variants

EDS460-D

Device version EDS460D utilizes a backlit graphical display where information can be displayed in different ways. This version is applied when detailed information about all devices in the switchboard cabinet, connected to the bus, are to be displayed locally. This device is capable of assigning parameters to all devices connected to the BMS bus and displaying all measurement details. Several EDS460D devices can be used in one system.

EDS460-L

Device version EDS490D/EDS490L utilizes a two-digit 7-segment display where the address of this device is displayed within the BMS bus. Various error codes are displayed too. The alarm LEDs indicate the measuring where the response value has been exceeded. Parameter setting is only possible via an EDS...D, an A-ISOMETER® IRDH575, the alarm and test combination MK2430 or the protocol converter FTC470XET.

EDS490-D/EDS490-L

The function of the device version EDS490D/EDS490L corresponds to the function described before. In addition, a galvanically isolated alarm contact (N/O contact) is provided, for example, to trigger a circuit breaker in this subcircuit when a response value has been exceeded.

EDS461-D/-L and EDS491-D/-L

The function of these device versions corresponds to the function described above, but these versions provide a higher response sensitivity. They are preferably used in control circuits or in medical locations up to AC 230 (DC 220) V.

Approvals



Overview of device types

Distinctive device features	EDS460-D/EDS461-D	EDS460-L/EDS461-L	EDS490-D/EDS491-D	EDS490-L/EDS491-L
Response values	EDS460: 2...10 mA EDS461: 0.2...1 mA		EDS490: 2...10 mA EDS491: 0.2...1 mA	
Display of residual current	EDS460: 100 mA...10 A EDS461: 10 mA...1 A		EDS490: 100 mA...10 A EDS491: 10 mA...1 A	
Backlit graphical display	×	--	×	--
7-segment display and LED line	--	×	--	×
Parameter setting function	×	--	×	--
Display error code	×			
Address range	1...90	1...90	1...90	1...90
Internal clock	×	--	×	--
History memory	×	--	×	--
Alarm contact "common alarm" for all channels	2 x 1 changeover contact	2 x 1 changeover contact	2 x 1 changeover contact	2 x 1 changeover contact
Alarm contact per channel	--		12 x 1 N/O contact	
Enclosure	XM460		XM490	

Wiring diagram – Operating elements EDS46...-D/-L und EDS49...-D/-L

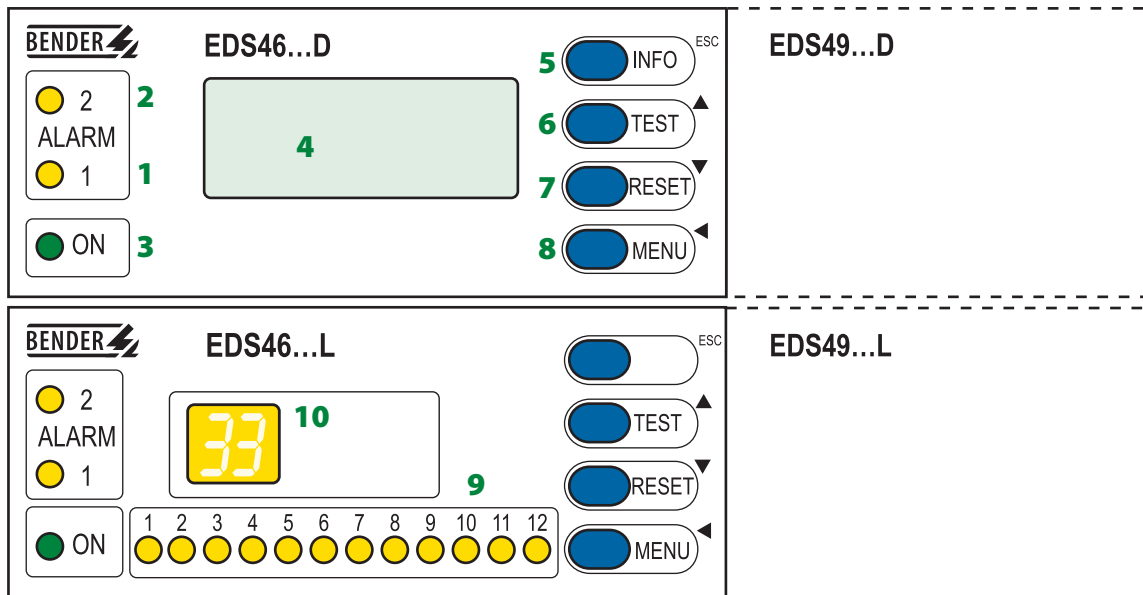

- 1 - Alarm LED 1 lights up in the event of the following system faults:
 - When the residual current exceeds > 10 A (EDS460/490) or > 1 A (EDS461/EDS491) (RCM function)
 - when there is a loss of power or short circuit in a measuring current transformer circuit (this function can be deactivated)
- 2 - Alarm LED 2 lights up when an insulation is detected in a channel (EDS function).
- 3 - Power On LED "ON"
- 4 - LC graphical display
- 5 - INFO key: to query standard information (does not apply to EDS...L). ESC key: back to MENU function
- 6 - TEST button: to call up the self test.
Arrow up key: Parameter change, scroll.
- 7 - RESET button: to acknowledge insulation and fault messages
Arrow down key: Parameter change, scroll.
- 8 - MENU key: EDS...-D: to toggle between the standard display, MENU and alarm indication
EDS...-L: sets the BMS address.
ENTER key: to confirm parameter change
- 9 - Alarm LEDs, light up if an insulation fault has been detected in the relevant channel.
- 10 - Digital indication for device address and error codes (parameter setting (EDS460/490-D only).

Wiring diagram – System connection EDS460/461-D/-L and EDS490/491-D/-L

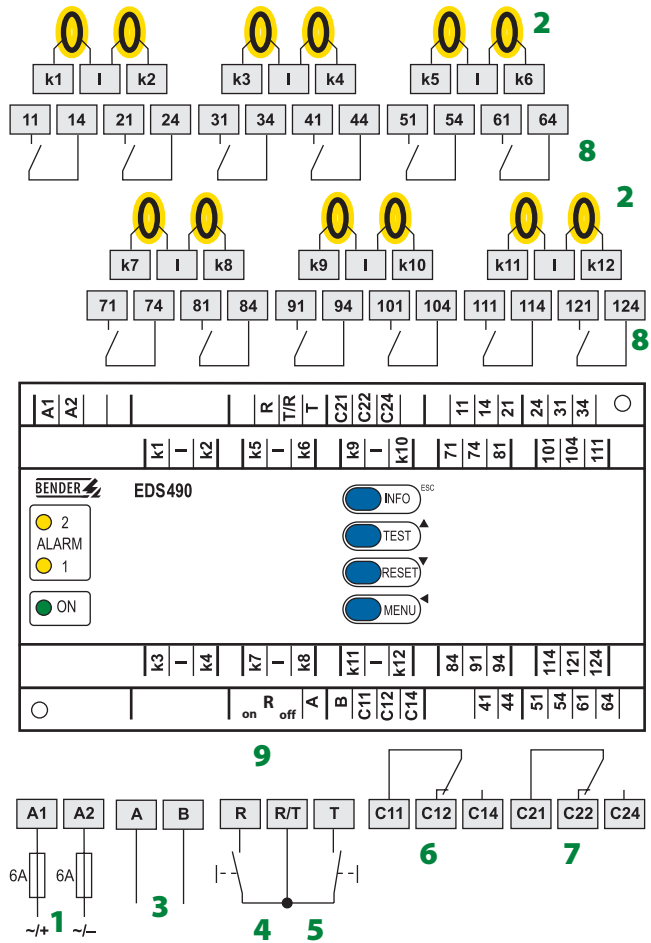
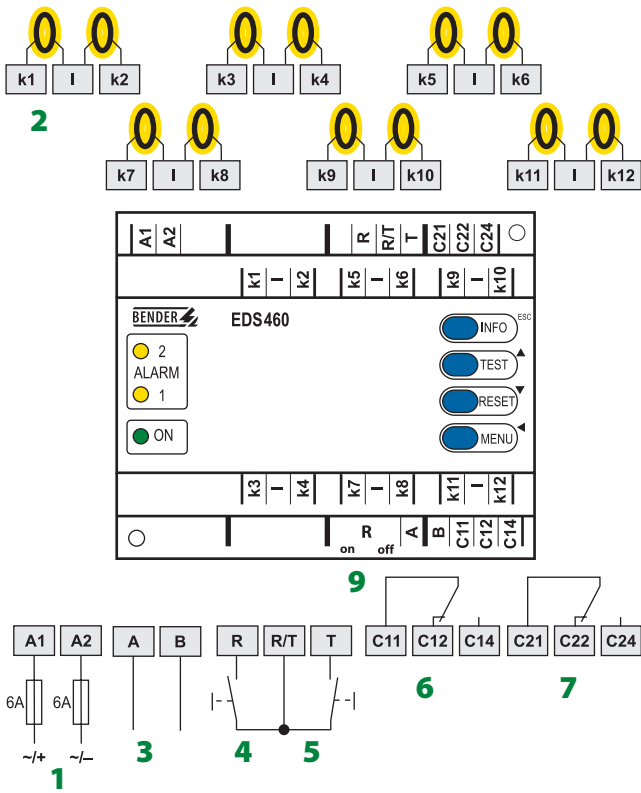

- 1 - Supply voltage U_s , see ordering information, 6 A fuse recommended. Two-pole fuses should be used on IT systems.
- 2 - Connection measuring current transformer k1...k12
- 3 - Serial RS-485 interface
- 4 - External reset button: "R" (N/O contact)*
- 5 - External test button: "T" (N/O contact)*

- 6 - Alarm relay 1
 - 7 - Alarm relay 2
 - 8 - Alarm relay: One N/O contact per channel (EDS490/491 only)
 - 9 - Ron/off: Termination of the serial RS-485 interface (A/B) with 120 Ω
- * The external test/reset buttons of several devices must not be connected to one another.

Technical data insulation fault evaluators EDS460/490 – EDS461/491

Insulation coordination acc. to IEC 60664-1

Rated insulation voltage	AC 250 V
Rated impulse voltage/pollution degree	4 kV / III
Protective separation (reinforced insulation) between (A1, A2) – (K1, L...K12, R/RT/T, AB) – (11, 12, 14) – (21, 22, 24)	
Voltage test according to IEC 61010-1	2.21 kV

Supply voltage

Supply voltage U_s	see ordering information
Frequency range	AC 42...460 Hz
Power consumption	≤ 10 VA (EDS460/461) ≤ 14 VA (EDS490/491)

Measuring circuit

Nominal system voltage U_n	see IRDH575, PGH
External measuring current transformers type	W... , WR... , WS... (EDS460, EDS490) W.../8000, WS.../8000 (EDS461, EDS491)
CT monitoring	on/off (on)*
Load	10 Ω
Rated insulation voltage (measuring current transformer)	800 V
Response sensitivity	2...10 mA (EDS460/ EDS490) 0.2...1 mA (EDS461/ EDS491)
Rated frequency	50/60/400 Hz
Measuring range EDS function	2...50 mA (EDS460/ EDS490) 0.2...5 mA (EDS461/ EDS491)
Measuring range RCM function	100 mA...10 A (EDS460/ EDS490) 10 mA...1 A (EDS461/ EDS491)
Number of measuring channels (per device/system)	12/1080

Specified time

Response delay t_{on}	0...24 s
Release delay t_{off}	0...24 s
Scanning time for all channels	approximately 4...10 s see TGH1394

EDS - measuring current transformer connection

Single wire $\geq 0.75 \text{ mm}^2$	0...1 m
Single wire, twisted $\geq 0.75 \text{ mm}^2$	1...10 m
Shielded cable $\geq 0.5 \text{ mm}^2$	10...40 m
Recommended cable	J-Y (ST) Y min. 2 x 0.8 (shielded, shield on one side connected to L-conductor , not connected to earth)

Displays, memory

LEDs	ON/ALARM (EDS...-D) ON/ALARM/Channel 1...12 (EDS...-L)
LC display	backlit graphical display (EDS...-D)
7-segment display	2 x 7.62 mm (EDS...-L)
History memory	300 data records (EDS...-D)
Password	off / 0...999 (off)*
Language	D, GB, F (GB)*
Fault memory alarm relay	on / off (off)*

Inputs/outputs

Test/reset button	internal/external
Cable length for external test / reset button	0...10 m

Interface

Interface/protocol	RS-485/BMS
Cable length	0...1200 m
Recommended cable (shielded, shield on one side connected to PE)	J-Y(ST)Y 2 x 0.8
Terminating resistor	120 Ω (0.25 W) via DIP switch connectable
Device address, BMS bus	DIP switch 1...90

Switching elements

Number of switching elements	Two relays with one changeover contact each (EDS460/461)				
	Two relays with one changeover contact each, 12 relays with one N/O contact each (EDS490/491)				
Operating principle	N/C or N/O operation (N/O operation)*				
Electrical service life, number of cycles	10.000				
Contact data acc. to IEC 60947-5-1					
Utilization category	AC-13	AC-14	DC-12	DC-12	DC-12
Rated operational voltage	230 V	230 V	24 V	110 V	220 V
Rated operational current	5 A	3 A	1 A	0.2 A	0.1 A
Minimum contact load	1 mA at AC / DC 10 V				

EMC

EMC	IEC 61326
Operating temperature	-25°C...+55°C
Climatic class acc. to IEC 60721	
Stationary use (IEC 60721-3-3)	3K5 (except condensation and formation of ice)
Transport (IEC 60721-3-2)	2K3 (except condensation and formation of ice)
Long-time storage (IEC 60721-3-1)	1K4 (except condensation and formation of ice)
Classification of mechanical conditions IEC 60731	
Stationary use (IEC 60721-3-3)	3M4
Transport (IEC 60721-3-2)	2M2
Long-time storage (IEC 60721-3-1)	1M3

Connection

Connection	screw-type terminals
rigid/flexible/conductor sizes	0.2...4/0.2...2.5 mm ² /12...24 AWG
Multi-conductor connection (2 conductors with the same cross section)	
rigid/flexible	0.2...1.5/0.2...1.5 mm ²
Stripping length	8...9 mm
Tightening torque	0.5...0.6 Nm

General Data

Operating mode	continuous operation
Position of normal use	any
Degree of protection, terminals (IEC 60529)	IP20
Enclosure material	polycarbonate
Flammability class	UL94V-0
Screw mounting	2 x M4
DIN rail mounting acc. to	IEC 60715
Product standards	DIN EN 61557-9: 2000-08 EN 61557-9: 1999-11, IEC 61557-9: 1999-09
Operating manual	BP108017/TGH1394
Weight	≤ 360 g (EDS46...) ≤ 510 g (EDS49...)

() * factory setting

Ordering information

Type	Supply voltage U_5^*	Response value	Art. No.
EDS460-D-1	DC 16...94 V AC 42...460 Hz 16...72 V	2...10 mA	B 9108 0001
EDS460-D-2	AC/DC 70...276 V AC 42...460 Hz	2...10 mA	B 9108 0002
EDS460-L-1	DC 16...94 V AC 42...460 Hz 16...72 V	2...10 mA	B 9108 0003
EDS460-L-2	AC/DC 70...276 V AC 42...460 Hz	2...10 mA	B 9108 0004
EDS461-D-1	DC 16...94 V AC 42...460 Hz 16...72 V	0.2...1 mA	B 9108 0005
EDS461-D-2	AC/DC 70...276 V AC 425...460 Hz	0.2...1 mA	B 9108 0006
EDS461-L-1	DC 16...94 V AC 42...460 Hz 16...72 V	0.2...1 mA	B 9108 0007
EDS461-L-2	AC/DC 70...276 V AC 42...460 Hz	0.2...1 mA	B 9108 0008
EDS490-D-1	DC 16...94 V AC 42...460 Hz 16...72 V	2...10 mA	B 9108 0009
EDS490-D-2	AC/DC 70...276 V AC 42...460 Hz	2...10 mA	B 9108 0010
EDS490-L-1	DC 16...94 V AC 42...460 Hz 16...72 V	2...10 mA	B 9108 0011
EDS490-L-2	AC/DC 70...276 V AC 42...460 Hz	2...10 mA	B 9108 0012
EDS491-D-1	DC 16...94 V AC 42...460 Hz 16...72 V	0.2...1 mA	B 9108 0013
EDS491-D-2	AC/DC 70...276 V AC 42...460 Hz	0.2...1 mA	B 9108 0014
EDS491-L-1	DC 16...94 V AC 42...460 Hz 16...72 V	0.2...1 mA	B 9108 0015
EDS491-L-2	AC/DC 70...276 V AC 42...460 Hz	0.2...1 mA	B 9108 0016

* Absolute values

Dimension diagrams XM460 and XM490

Dimensions are given in mm

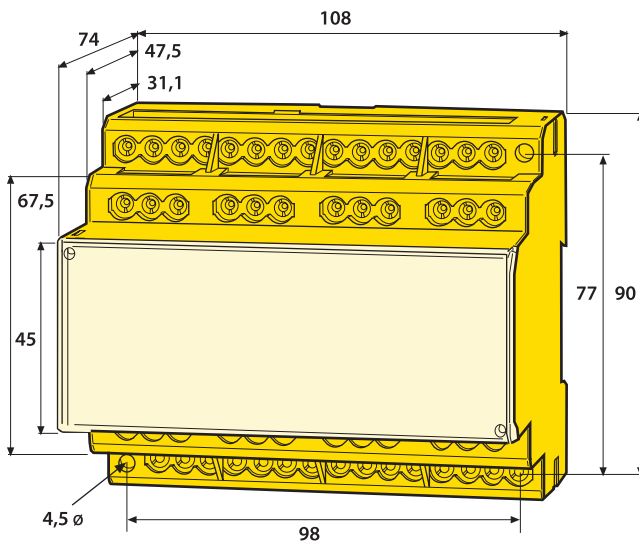
EDS46...-D/-L – XM460

EDS49...-D/-L – XM490
