

# CSE141

## Overcurrent relay for AC currents



CSE141

### Device features

- Overcurrent relay for AC currents
- External supply voltage
- 4 device variants with adjustable response values: 0.5...5 A, 1...10 A, 5...50 A, ...A (with STW2)
- Adjustable response delay 0.1...10 s
- Adjustable hysteresis 2...10 %
- Direct reading scales
- Power On LED, alarm LED
- Alarm relay with two potential-free changeover contacts
- 45 mm enclosure

### Note

In case of new installations refer to CME420.

### Approvals



### Product description

The undercurrent relays of the CSE141 series monitor the overcurrent in AC systems. External supply voltage is required. The response value, response delay and hysteresis are set via potentiometers.

### Typical applications

- Monitoring the load and functionality of electric loads
- Power consumption monitoring
- Monitoring of lighting circuits, screw conveyors, dust removal etc.
- On/off switching of loads when a certain voltage value is reached

### Function

The current to be monitored is connected to the terminals K and L. If the current exceeds the set response value "Y", the alarm relay switches after the response delay has elapsed and the alarm LED "I>Y" lights up. When the measured quantity drops below the set response value plus hysteresis "Hy", the alarm relay switches back to its original state within approximately 70 ms. The operating principle of the alarm relay can be set to N/O or N/C operation.

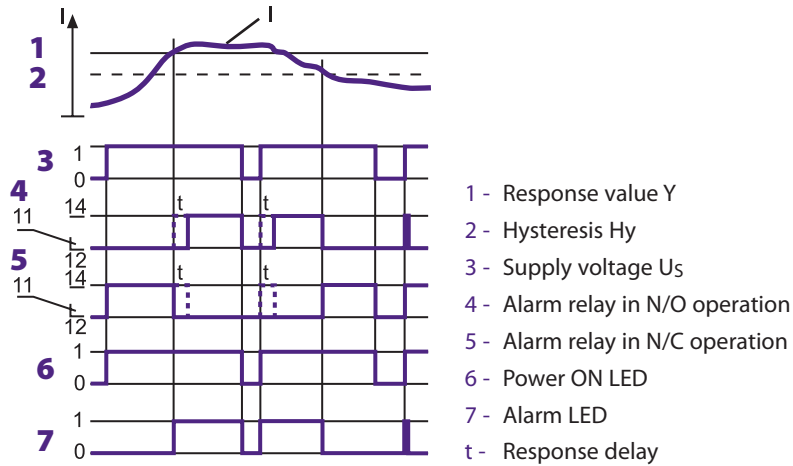

### Note

False alarms resulting from operational measurement errors can be suppressed by setting a time delay. The set response delay remains effective even in case of complete supply voltage failure.

### Ordering information

Type	Supply voltage $U_s$	Response value	Art. No.
CSE141	AC 50...60 Hz / 85...275 V	0.1...10 A	B 942 615
CSE141	AC 50...60 Hz / 85...275 V	0,5...5 A	B 942 613
CSE141	AC 50...60 Hz / 85...275 V	1...10 A	B 942 611
CSE141	AC 50...60 Hz / 85...275 V	5...50 A	B 942 191
CSE141	AC 50...60 Hz / DC 9.6...84 V	0.1...1 A	B 942 627
CSE141	AC 50...60 Hz / DC 9.6...84 V	0,5...5 A	B 942 251
CSE141	AC 50...60 Hz / DC 9.6...84 V	1...10 A	B 942 370
CSE141	AC 50...60 Hz / DC 77...286 V	1...10 A	B 942 806
CSE141	AC 50...60 Hz / DC 77...286 V	0.5...5 A	B 942 621
CSE141	AC 50...60 Hz / DC 77...286 V	1...10 A	B 942 807
Measuring current transformer STW2 for B 942 191			B 942 709

### Accessories

Mounting rail for screw fixing	B 974 728
--------------------------------	-----------

### Dimension diagram X140 Dimensions in mm

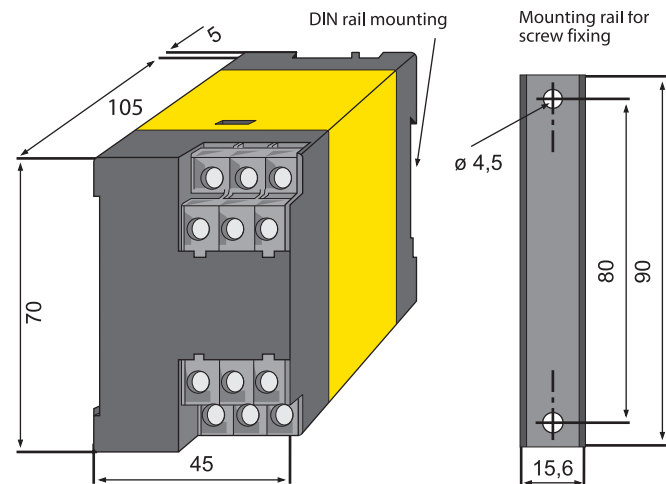



**Wiring diagram**

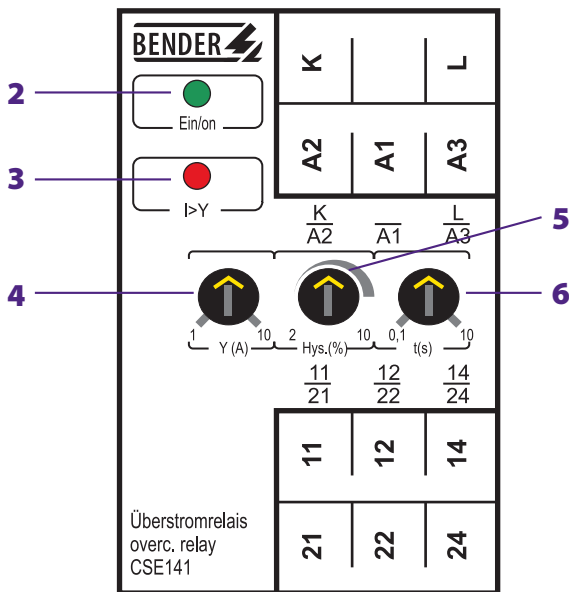
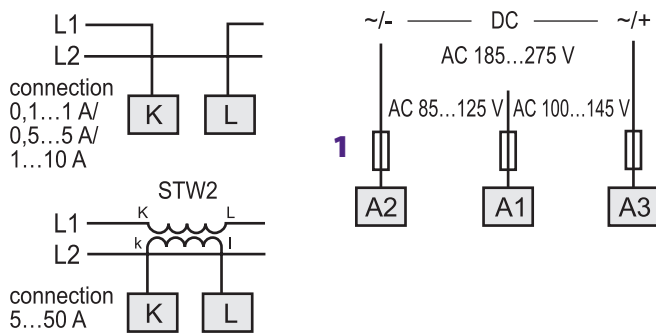

- 1 - 6 A fuse
- 2 - Power ON LED "Ein/on"
- 3 - Alarm LED "I>Y"
- 4 - Adjustable response value "Y(A)"
- 5 - Adjustable hysteresis "Hys(%)"
- 6 - Adjustable response delay "t(s)"
- 7 - Alarm relay

**Setting of the operating principle of the alarm relay**

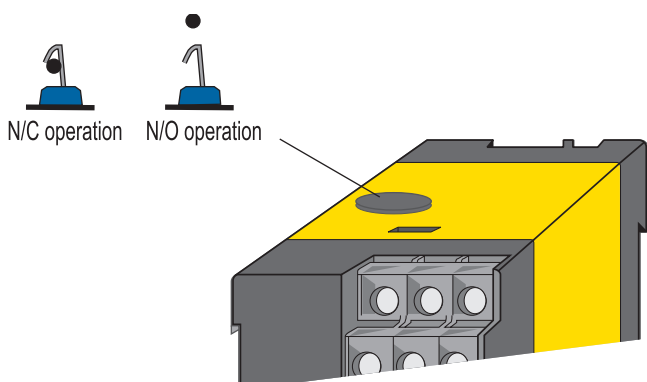

**Technical data undercurrent relay CSE141**

**Insulation coordination acc. to IEC 60664-1**

Rated insulation voltage	AC 440 V
Rated impulse voltage/pollution degree	4 kV/3

**Supply voltage**

Supply voltage $U_s$	see ordering information
Power consumption	$\leq 3$ VA

**Measuring circuit**

Frequency $f_n$	50...60 Hz
Response values	0.1...1 A 0.5...5 A 1...10 A 5...50 A (with STW2)

Overload capability	40 A 1 s / 12 A DB Transformer 10 x $I_n$
Response delay t	0.1...10 s (0.1)*
Hysteresis, adjustable	2...10 % (2%)*
Delay on release	approx. 70 ms
Repetition accuracy	$\pm 1.5$ %
Temperature influence	$< 0.05$ % / °C
Recovery time $t_b$	$\leq 200$ ms

**Switching elements**

Number of changeover contacts	1 x 2
Operating principle	N/C operation/ N/O operation (N/O operation)*
Electrical service life, number of cycles	12000
Contact class IEC 60255 Part 0-20	IIB
Rated contact voltage	AC 250 V/DC 300 V
Limited making capacity	AC/DC 5 A
Breaking capacity	2 A, AC 230 V, cos phi 0.4 0.2 A, DC 220 V, L/R = 0.04 s

**Environment / EMC**

EMC immunity	acc. to IEC 61000-6-2
EMC emission	acc. to IEC 61000-6-4
Shock resistance IEC 60068-2-27 (during operation)	15 g/11 ms
Bumping IEC 60068-2-29 (during transport)	40 g/6 ms
Vibration resistance IEC 60068-2-6 (during operation)	1 g / 10...150 Hz
Vibration resistance IEC 60068-2-6 (during transport)	2 g / 10...150 Hz
Ambient temperature, during operation	-15...+50 °C
Ambient temperature, during storage	-20...+70 °C
Climatic class acc. to IEC 60721-3-3	3K5 (except condensation and formation of ice)

**Other**

Operating mode	continuous operation
Mounting	any position
Connection	Flat terminals with self-lifting clamp washers
Connection properties	
single wire	2 x (1...1.5) mm <sup>2</sup>
flexible with end ferrule	2 x (0.75...1.5) mm <sup>2</sup>
Degree of protection, internal components (IEC 60529)	IP50
Degree of protection, terminals/with terminal covers (IEC 60529)	IP10/IP20
Screw fixing	with mounting rail
DIN rail mounting acc. to	IEC 60715
Flammability class	UL94V-0
Product standard	IEC 60255-6
Operating manual	BP306003
Weight	$\leq 250$ g

( ) \* factory setting