

Ground Fault Monitor RCMA420

AC / DC ground fault monitor
for grounded systems
(AC, DC and pulsed DC currents)



RCMA420

Device features

- AC / DC sensitive ground fault current monitor - Type B according to IEC 62020 and IEC 60755
- r.m.s. value measurement (AC + DC)
- Two separately adjustable response values 30...500 mA
- Frequency range 0...2000 Hz
- Starting delay, response delay and delay on release
- Digital measured value display via LC display
- Measured value memory for tripping value
- CT connection monitoring
- Power On LED, LED Alarm 1 / 2
- TEST / RESET button, internal / external
- Two separate alarm relays (one change-over contact each)
- Failsafe and Non-failsafe relay mode and fault memory selectable
- Continuous self monitoring
- Multi-functional LC display.
- Password protection for device settings
- Sealable transparent cover
- Two-module enclosure (36 mm)
- RoHS conform

Approvals



Product description

The AC / DC sensitive ground fault current monitor RCMA420 is designed for monitoring grounded & high-resistance grounded power supply systems where AC and DC ground fault currents may occur. These are in particular loads containing six-pulse rectifiers or one way rectifiers with smoothing, such as converters, battery chargers, construction site equipment with frequency-controlled drives (VFDs). Currents in single conductors can be monitored as well in certain applications.

The prewarning stage (50...100% of the set response value $I_{\Delta n2}$) allow to distinguish between prewarning and alarm. Since the values are measured with measuring current transformers, the device is nearly independent of the load current and the nominal voltage of the system.

Applications

- AC / DC sensitive ground fault (residual) current monitoring in grounded and high-resistance grounded two, three or four conductor systems (AC or DC).
- Monitoring of variable-speed drives, UPS systems, construction site equipment, printing machines, battery systems, laboratory equipment, wood working machines, MF welding systems, medical electrical equipment, mining equipment, fountains, etc.
- AC / DC sensitive current monitoring of single conductors de-energized under normal conditions (e. g. N and GND/PE conductors)

Function

Once the supply voltage U_S is applied, the starting delay is activated. Measured values changing during this time do not influence the switching state of the alarm relays.

Residual current measurement takes place via an external measuring current transformer of the W20AB...W60AB series. The currently measured value is shown on the LC display. In this way any changes, for example when circuits are connected to the system, can be recognized easily. If the measured value exceeds one or both response values, the response delay " $t_{on1/2}$ " starts running. Once the response delay " $t_{on1/2}$ " has elapsed, the "K1 / K2" alarm relays switch and the alarm LEDs "AL1 / AL2" light up. If the current falls below the release value (response value plus hysteresis), the release delay " t_{off} " begins. Once the release delay " t_{off} " has elapsed, the alarm relays return to their original state and the alarm LEDs AL1 / AL2 go out. If the fault memory is enabled, the alarm relays remain in the alarm state and the LEDs light until the reset button is pressed or until the supply voltage is interrupted. The device function can be tested using the TEST button. The parameterization of the device can be carried out via the LC display and the function keys integrated in the front plate and can be password-protected.

Connection monitoring

The function of the device and the CT connections are continuously monitored. In the event of a fault, the alarm relays K1 / K2 switch without delay, the alarm LEDs AL1 / AL2 / ON flash. After eliminating the fault, the alarm relays return to their original state either automatically or by pressing the reset button.

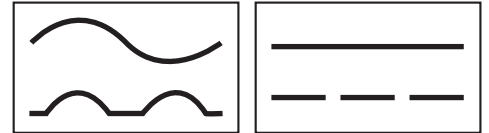

Operating and display elements

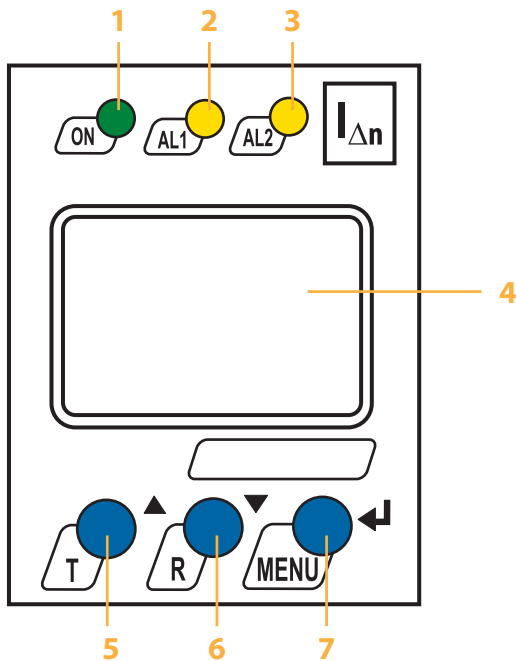

- 1 - Power "ON" LED (green); lights after connecting the device to the supply voltage and flashes in the event of system fault alarm respectively in the event of CT malfunction.
- 2 - Alarm LED "AL1" (yellow), prewarning; lights when the set response value $I_{\Delta n1}$ has been exceeded or flashes in the event of system fault alarm respectively in the event of CT malfunction.
- 3 - Alarm LED "AL2" (yellow), Alarm; lights when the set response value $I_{\Delta n2}$ has been exceeded or flashes in the event of system fault alarm respectively in the event of CT malfunction.
- 4 - Multi-functional LC display
- 5 - TEST button: to call up the self test
Arrow up key: parameter change, to move up in the menu
- 6 - RESET button: to delete saved alarms
Arrow down key: parameter change, to move down in the menu
- 7 - MENU key: to call up the menu system
Enter key: to confirm parameter change
Press ESC: key > 1.5 s.

Wiring diagram

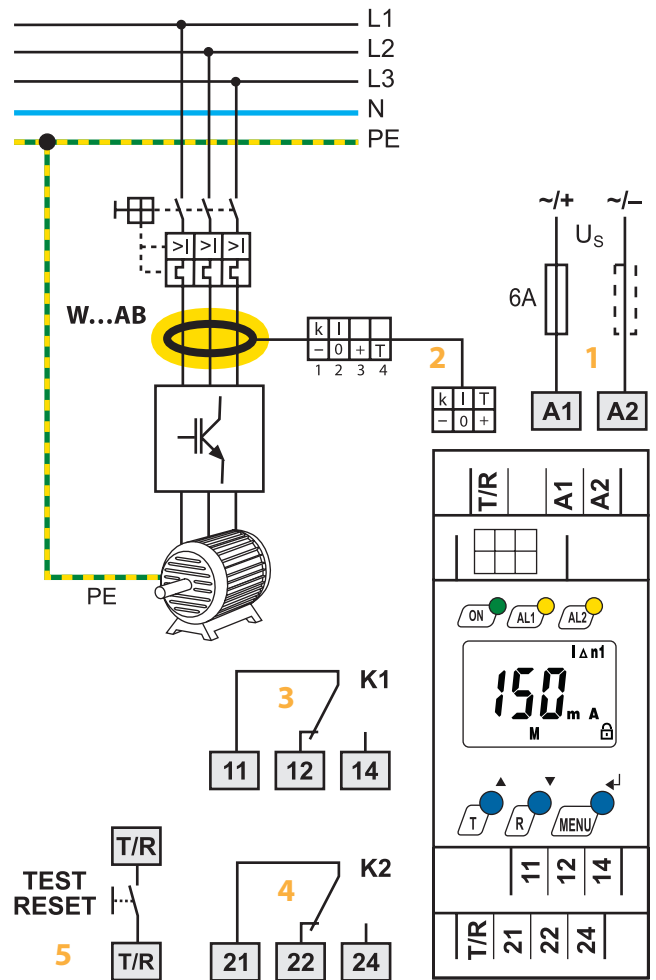

- 1 - Supply voltage U_s (see ordering information), a 6 A fuse recommended for line protection.
- 2 - Connector for the external measuring current transformer W20AB...W60AB.
- 3 - Alarm relay K1: $I_{\Delta n1}$ (prewarning).
- 4 - Alarm relay K2: alarm $I_{\Delta n2}$ (alarm).
- 5 - Combined TEST and RESET button, short-time pressing (< 1.5 s) = RESET, long-time pressing (> 1.5 s) = TEST.

Note! Do not route the ground conductor (GND/PE) through the measuring current transformer!

Connection of measuring current transformers

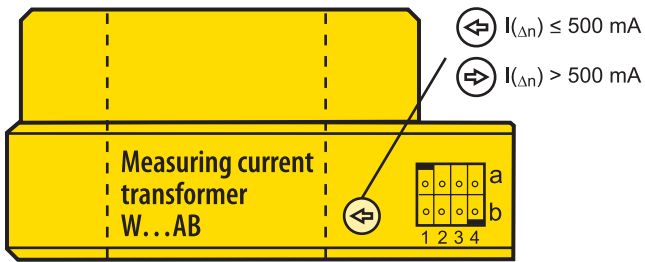

4.2

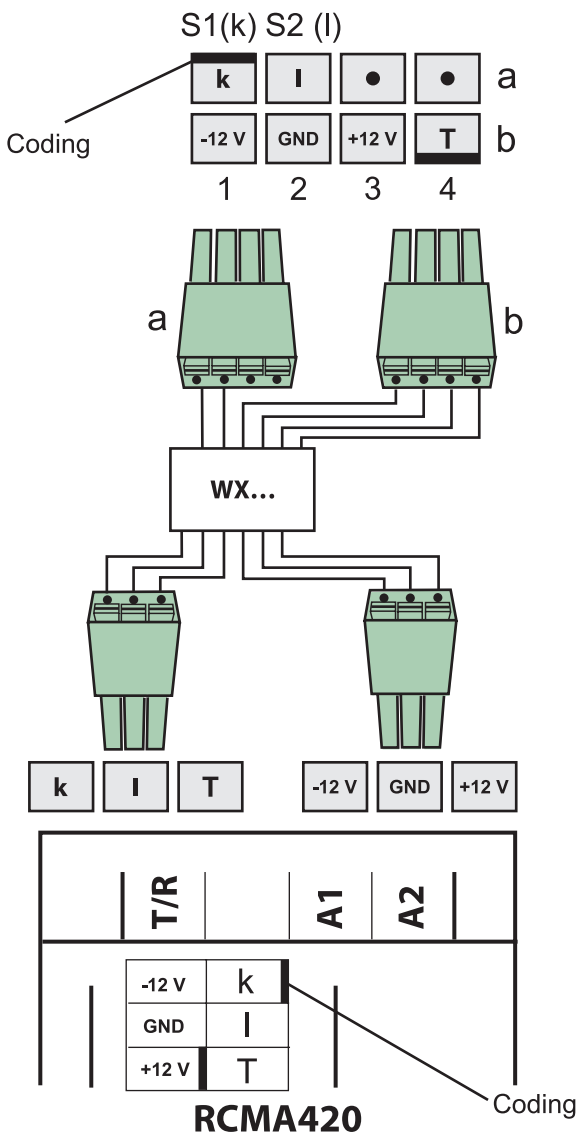

Dimension diagram XM420

Open the front plate cover in direction of arrow!
Dimensions in mm

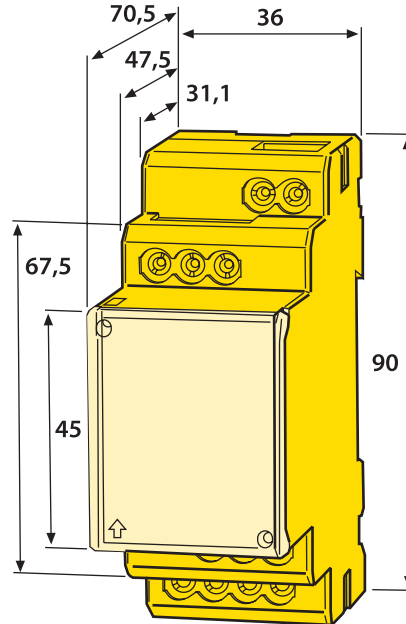

Screw mounting

Note: The upper mounting clip must be ordered separately (see ordering information).

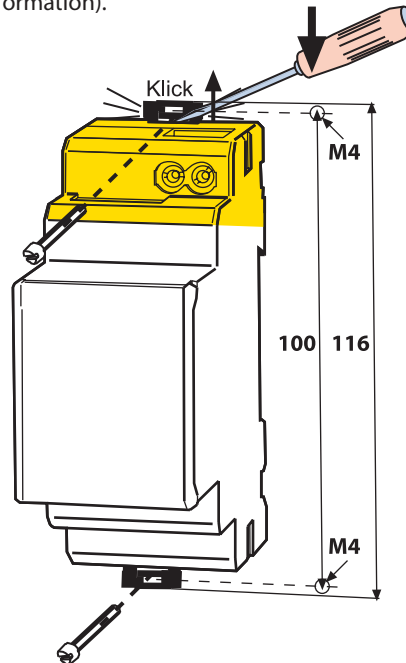

Technical data

Insulation coordination acc. to IEC 60664-1 / IEC 60664-3	
Rated insulation voltage	250 V
Rated impulse voltage / pollution degree	2.5 kV / III
Protective separation (reinforced insulation) between (A1, A2) – (k / I / - / 0 / +, T / R) – (11, 12, 14) – (21, 22, 24)	
Voltage test according to IEC 61010-1	2.21 kV
Supply voltage	
Supply voltage U_5	see ordering information
Power consumption	≤ 3 VA
Measuring circuit	
External measuring current transformer	W20AB, W35AB, W60AB series
Rated insulation voltage (measuring current transformer)	800 V
Operating characteristic acc. to IEC 60755	Type B
Rated frequency	0...2000 Hz
Measuring range	3...500 mA
Relative percentage error of measuring value	0...-35 %
Display accuracy of measuring value	± 17.5 %
Response values	
Rated residual operating current $I_{\Delta n1}$ (prewarning)	50...100 % of $I_{\Delta n2}$ (15 mA)*
Rated residual operating current $I_{\Delta n2}$ (Alarm)	10...500 mA (30 mA)*
Hysteresis	10...25 % (15 %)*
Specified time	
Starting delay t	0...10 s (0 s)*
Response delay t_{on2} (alarm)	0...10 s (0 s)*
Response delay t_{on1} (prewarning)	0...10 s (1 s)*
Delay on release t_{off}	0...99 s (1 s)*
Operating time t_{ae} at $I_{\Delta n} = 1 \times I_{\Delta n1} / 2 / I_{\Delta n} = 5 \times I_{\Delta n1} / 2$	≤ 180 ms / ≤ 30 ms
Response time	$t_{an} = t_{ae} + t_{on1} / 2$
Recovery time t_b	≤ 300 ms
Displays, memory	
Display range, measured value	0...500 mA
Relative percentage error	0...-35 % / ± 2 digit
Measured-value memory for alarm value	data record measured values
Password	off / 0...999 (off)*
Fault memory behaviour	ON / OFF (ON)*
Inputs / outputs	
Cable length for external TEST / RESET button	0...10 m

Cable lengths for measuring current transformers

Single wire 6 x 0.75 mm ²	0...10 m
Connection	connectors WX... recommended

Switching elements

Number of switching elements	2 x 1 changeover contact				
Operating principle	N / C operation or N / O operation (N / O operation)*				
Electrical service life under rated operating conditions	10.000 switching operations				
Contact data acc. to IEC 60947-5-1					
Utilization category	AC-13	AC-14	DC-12	DC-12	DC-12
Rated operational voltage	230 V	230 V	24 V	110 V	220 V
Rated operational current	5 A	3 A	1 A	0,2 A	0,1 A
Minimum contact load	1 mA at AC / DC ≥ 10 V				

Environment / EMC

EMC	IEC 62020	
Operating temperature	-25 °C...+55 °C	
Climatic class acc. to IEC 60721		
Stationary use (IEC 60721-3-3)	3K5 (except condensation and formation of ice)	
Transport (IEC 60721-3-2)	2K3 (except condensation and formation of ice)	
Long-time storage (IEC 60721-3-1)	1K4 (except condensation and formation of ice)	
Classification of mechanical conditions IEC 60721		
Stationary use (IEC 60721-3-3)	3M4	
Transport (IEC 60721-3-2)	2M2	
Long-time storage (IEC 60721-3-1)	1M3	

Connection

Connection	screw terminals	
rigid / flexible / conductor sizes	0.2...4 / 0.2...2.5 mm ² / 24...12 AWG	
Multi-conductor connection (2 conductors with the same cross section)		
rigid / flexible	0.2...1.5 / 0.2...1.5 mm ²	
Stripping length	8...9 mm	
Tightening torque	0.5...0.6 Nm	

Other

Operating mode	continuous operation
Position of normal use	any
Degree of protection, internal components / terminal (IEC 60529)	IP30 / IP20
Enclosure material	polycarbonate
Flammability class	UL94V-0
DIN rail mounting acc. to	IEC 60715
Screw mounting	2 x M4 with mounting clip
Standards	IEC 62020
Instruction leaflet	TGH1411
Weight	≤ 150 g

() * Factory setting

Ordering information

Type	Response range $I_{\Delta n}$	Frequency range	Supply voltage U_5 *	Art. No.
RCMA420-D-1	30...500 mA	0...2000 Hz	DC 9.6...94 V/ AC 42...460 Hz 16...72 V	B 9404 3001
RCMA420-D-2	30...500 mA	0...2000 Hz	DC 70...300 V/ AC 42...460 Hz 70...300 V	B 9404 3002

* Absolute values

Measuring current transformers

Type	Inside diameter (mm)	Art. No.
W20AB	ø 20	B 9808 0008
W35AB	ø 35	B 9808 0016
W60AB	ø 60	B 9808 0026

Connection cable measuring current transformer – RCMA420-D

Type	Length / m	Art. No.
WX-100	1	B 9808 0503
WX-250	2.5	B 9808 0504
WX-500	5	B 9808 0505

Accessories

Type	Art. No.
Mounting clip for enclosure XM420	B 9806 0008
Snap-on mounting for W20... / W35...	B 9808 0501
Snap-on mounting for W60...	B 9808 0502
(1 unit required for each device)	