

Ground fault current monitor RCM420

Ground Fault Current Monitor
for grounded systems
(AC and pulsed DC currents)



RCM420

Device features

- AC and pulsed DC sensitive residual current monitor Type A according to IEC 62020
- r.m.s. value measurement (AC)
- Two separately adjustable response values
- Frequency range 42...2000 Hz
- Starting delay, response delay and delay on release
- Restart function
- Measured value display via LC display
- Measured value memory for operating value
- CT connection monitoring
- Power On LED, LED Alarm 1 / 2
- TEST / RESET button, internal / external
- Two separate alarm relays (one SPDT for each alarm)
- Failsafe/Non-failsafe relay mode and fault memory behaviour selectable
- Password protection for device setting
- Device self monitoring
- Sealable transparent cover
- Two-module enclosure (36 mm)
- RoHS conform

Approvals



Product description

The digital ground fault monitor RCM420-D... monitors for ground fault leakage current in grounded & high-resistance grounded single & three-phase AC and pulsed DC systems. Ungrounded systems require special consideration (please call for more information). The RCM420 series is specially designed to provide advanced warning of developing faults without the problems associated with nuisance tripping. It is an IEC 62020 Type A device. The prewarning stage (50...100% of the set response value $I_{\Delta n2}$) allow to distinguish between prewarning and alarm. Since the values are measured with measuring current transformers, the device is nearly independent of the load current and the nominal voltage of the system.

Applications

- Ground fault current monitoring in grounded two, three or four conductor systems.
- Current monitoring of single conductors de-energized under normal conditions.
- Socket-outlet circuits for devices which are operated unattended for a long time and which may not fail.
- Alarm systems, safety devices
- Air conditioning systems, EDP systems
- Cooling equipment with valuable frozen goods
- Fountains
- Monitoring of grounded (earthed) power supplies for stray currents
- Can also be used to monitor neutral load current
- Trace heating systems

Function

Once the supply voltage U_S is applied, the starting delay "t" is activated. Measured values exceeded during this time do not influence the switching state of the alarm relays.

Ground fault current monitoring takes place via an external measuring current transformer. The currently measured value is shown on the LC display. In this way any changes, for example when circuits are connected to the system, can be recognized easily.

If the measured value exceeds one or both response values, the response delay $t_{on1/2}$ starts running. After the expiry of the response delay $t_{on1/2}$, the selected alarm relays switch and the alarm LEDs light. If the release value is not reached before the expiry of "t_{on}", the alarm LEDs "AL1 / AL2" do not light and the alarm relays do not switch. The set release time "t_{off}" starts running when the measured value again falls below the release value (response value plus hysteresis) after the switching of the alarm relays. After the expiry of "t_{off}", the alarm relays switch back to their initial position. If the fault memory is enabled, the alarm relays remain in the alarm state until the reset button R is pressed or until the supply voltage is interrupted. The device function can be tested using the TEST button. The parameterization of the device can be carried out via the LC display and the function keys integrated in the front plate and can be password-protected.

Connection monitoring

The CT connections are continuously monitored. In the event of a fault, the alarm relays K1 / K2 switch without delay, the alarm LEDs AL1 / AL2 / ON flash. After eliminating the fault, the alarm relays return to their initial position either automatically or by pressing the reset button (fault memory behaviour).

Restart function

If an alarm is pending after resetting the alarm relay and restarting the system being monitored, this reset process is repeated until the preset number of restart cycles is completed. As soon as the preset number of restart cycles is completed, the fault memory is set to ON.

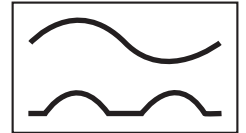

Operating and display elements

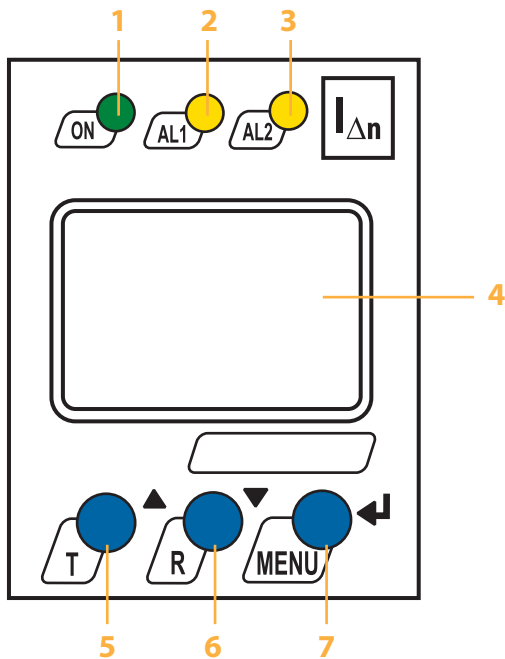

- 1 - Power "ON" LED (green); lights after connecting the device to the supply voltage and flashes in the event of system fault alarm respectively in the event of CT malfunction.
- 2 - Alarm LED "AL1" (yellow), prewarning, lights when the set response value $I_{\Delta n1}$ has been exceeded or flashes in the event of system fault alarm respectively in the event of CT malfunction.
- 3 - Alarm LED "AL2" (yellow), alarm, lights when the set response value $I_{\Delta n2}$ has been exceeded and flashes in the event of system fault alarm and in the event of CT malfunction.
- 4 - Multi-functional LC display.
- 5 - TEST button: to call up the self test.
Arrow up key: parameter change, to move up in the menu.
- 6 - RESET button: to delete saved alarms.
Down key: Arrow down key: parameter change, to move down in the menu.
- 7 - MENU key: to call up the menu system.
Enter key: to confirm parameter change.
Press ESC: key > 1.5 s.

Wiring diagram

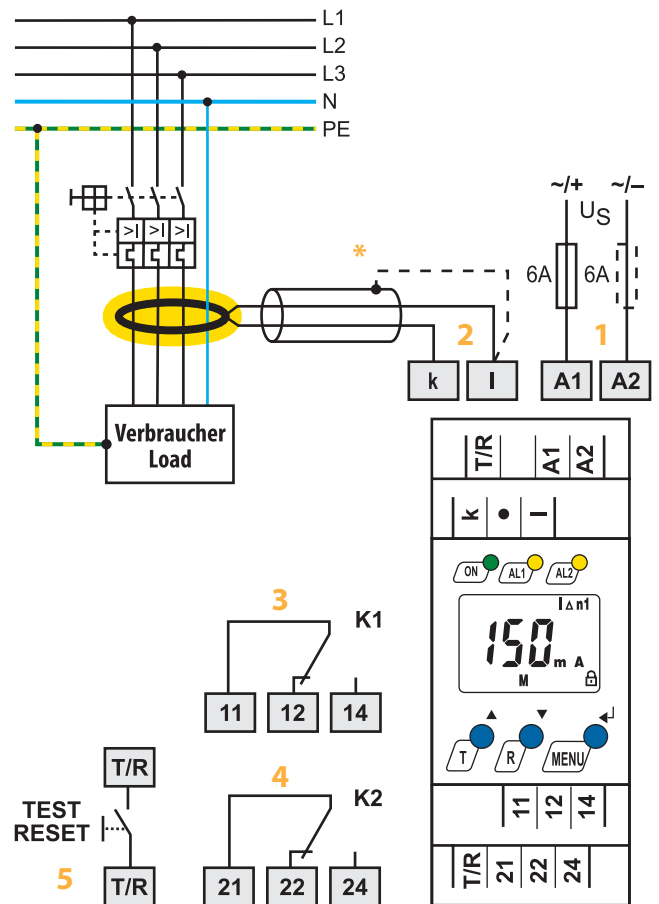

- 1 - Supply voltage U_S (see ordering information), a 6 A fuse recommended for line protection.
- 2 - Connection of the external measuring current transformer
- 3 - Alarm relay K1: programmable for $I_{\Delta n1}$ / $I_{\Delta n2}$ / TEST / ERROR
- 4 - Alarm relay K2: programmable for $I_{\Delta n1}$ / $I_{\Delta n2}$ / TEST / ERROR
- 5 - Combined TEST and RESET button, short-time pressing (< 1.5 s) = Reset, long-time pressing (> 1.5 s) = Test
- * - when a shielded cable is used.

Do not route the ground conductor (GND/PE) through the measuring current transformer!

Technical data

Insulation coordination acc. to IEC 60664-1 / IEC 60664-3	
Rated insulation voltage	250 V
Rated impulse voltage / pollution degree	2.5 kV / III
Protective separation (reinforced insulation) between (A1, A2) - (k / I, T / R) - (11, 12, 14) - (21, 22, 24)	
Voltage test according to IEC 61010-1	2.21 kV
Supply voltage	
Supply voltage U_S	see ordering details
Power consumption	≤ 3 VA
Measuring circuit	
External measuring current transformer	W..., WR..., WS... series
Load	68 Ω
Rated insulation voltage (measuring current transformer)	800 V
Operating characteristic acc. to IEC 62020	Type A
Rated frequency	42...2000 Hz
Measuring range	3 mA...16 A
Relative percentage error	0...-20 %
Display accuracy	± 15 %
Response values	
Rated residual operating current $I_{\Delta n1}$ (prewarning)	50...100 % x $I_{\Delta n2}$ (50 %)*
Rated residual operating current $I_{\Delta n2}$ (alarm)	10 mA...10 A (30 mA)*
Hysteresis	10...25 % (15 %)*
Specified time	
Starting delay t	0...10 s (0,5 s)*
Response delay t_{on2} (alarm)	0...10 s (0 s)*
Response delay t_{on1} (prewarning)	0...10 s (1 s)*
Delay on release t_{off}	0...99 s (1 s)*
Operating time t_{ae} at $I_{\Delta n} = 1 \times I_{\Delta n1/2}$	≤ 180 ms
Operating time t_{ae} at $I_{\Delta n} = 5 \times I_{\Delta n1/2}$	≤ 30 ms
Response time t_{an}	$t_{an} = t_{ae} + t_{on1/2}$
Recovery time t_b	≤ 300 ms
Number of restart cycles	0...100 (0)*
Cable lengths for measuring current transformers	
Single wire ≥ 0.75 mm ²	0...1 m
Single wire, twisted ≥ 0.75 mm ²	0...10 m
Shielded cable ≥ 0.5 mm ²	0...40 m
Recommended cable (shielded, shield on one side connected to terminal I of the RCM420, not connected to earth)	J-Y(ST)Y min. 2 x 0.8
Connection	screw terminals
Displays, memory	
Display range, measuring value	3 mA...16 A
Relative percentage error	0...-30 % / ± 2 digit
Measured-value memory for alarm value	data record measured values
Password	off / 0...999 (off)*
Fault memory behaviour	ON / OFF (ON)*

Inputs / outputs

Cable length for external test / reset button	0...10 m
---	----------

Switching elements

Number of switching elements	2 x 1 changeover contact				
Operating principle	N / C operation or N / O operation (N / O operation)*				
Electrical service life under rated operating conditions	10.000 switching operations				
Contact data acc. to IEC 60947-5-1					
Utilization category	AC-13	AC-14	DC-12	DC-12	DC-12
Rated operational voltage	230 V	230 V	24 V	110 V	220 V
Rated operational current	5 A	3 A	1 A	0.2 A	0.1 A
Minimum contact load	1 mA at AC / DC ≥ 10 V				

Environment / EMC

EMC	IEC 62020: 2003-11	
Operating temperature	-25 °C...+55 °C	
Climatic class acc. to IEC 60721		
Stationary use (IEC 60721-3-3)	3K5 (except condensation and formation of ice)	
Transport (IEC 60721-3-2)	2K3 (except condensation and formation of ice)	
Long-time storage (IEC 60721-3-1)	1K4 (except condensation and formation of ice)	
Classification of mechanical conditions IEC 60721		
Stationary use (IEC 60721-3-3)	3M4	
Transport (IEC 60721-3-2)	2M2	
Long-time storage (IEC 60721-3-1)	1M3	

Connection

Connection	screw terminals
rigid / flexible / conductor sizes	0.2...4 / 0.2...2.5 mm ² / 24...12 AWG
Multi-conductor connection (2 conductors with the same cross section)	
rigid / flexible	0.2...1.5 / 0.2...1.5 mm ²
Stripping length	8...9 mm
Tightening torque	0.5...0.6 Nm

Other

Operating mode	continuous operation
Position of normal use	any
Degree of protection, internal components (IEC 60529)	IP30
Degree of protection, terminals (IEC 60529)	IP20
Enclosure material	polycarbonate
Flammability class	UL94V-0
DIN rail mounting acc. to	IEC 60715
Screw mounting	2 x M4 with mounting clip
Standards	IEC 62020
Instruction leaflet	TGH1410
Weight	≤ 150 g

() * factory setting

Ordering information

Type	Response range $I_{\Delta n}$	Frequency range	Measuring current transformers	Supply voltage U_S *	Art. No.
RCM420-D-1	10 mA...10 A	42...2000 Hz	W..., WR..., WS...	DC 9.6...94 V / AC 42...460 Hz 16...72 V	B 9401 4001
RCM420-D-2	10 mA...10 A	42...2000 Hz	W..., WR..., WS...	DC 70...300 V / AC 42...460 Hz 70...300 V	B 9401 4002

* absolute values

External measuring current transformers

Type	Inside diameter (mm)	Art. No.
W20	ø 20	B 9808 0003
W35	ø 35	B 9808 0010
W60	ø 60	B 9808 0018
W120	ø 120	B 9808 0028
W210	ø 210	B 9808 0034
WR70x175	70 x 175	B 9808 0609
WR115x305	115 x 305	B 9808 0610
WS20x30	20 x 30	B 9808 0601
WS50x80	50 x 80	B 9808 0603
WS80x120	80 x 120	B 9808 0606

Other measuring current transformer types on request.

Accessories

Type	Art. No.
Mounting clip for enclosure XM420 (1 piece per device)	B 9806 0008
Snap-on mounting for W20.../W35...	B 9808 0501
Snap-on mounting for W60...	B 9808 0502

Dimension diagram XM420

Dimensions in mm
Open the front plate cover in direction of arrow!

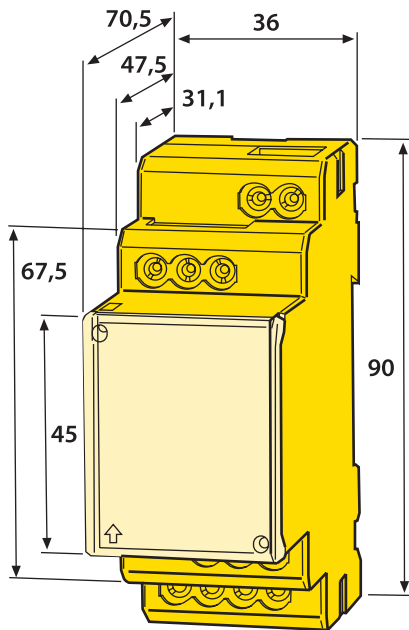

Screw mounting

Note: The upper mounting clip must be ordered separately (see ordering information).

