



- 3Ph/N AC systems
- monitoring under voltages from



- electronic measuring relay
- no additional supply voltage required
- alarm relay with two change over contacts
- built-in power on LED and alarm LED
- continuously adjustable alarm points
- compact 45 mm casing
- monitors Line to Neutral voltages

### Function

If one, two or all line-to-neutral voltages fall below the adjusted response value "Y", the alarm relay releases out and the red alarm LED signals "UVW Æ N<Y".

If the adjusted response value and additionally the fixed hysteresis "Hy" is exceeded the alarm relay reacts and the red alarm LED extinguishes.

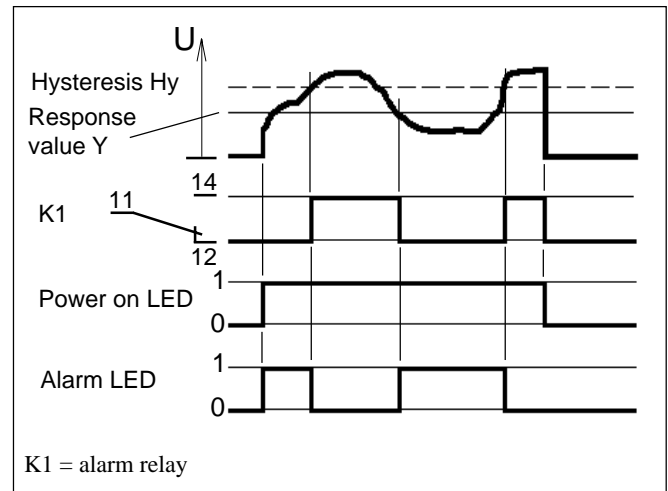

### Delay on response

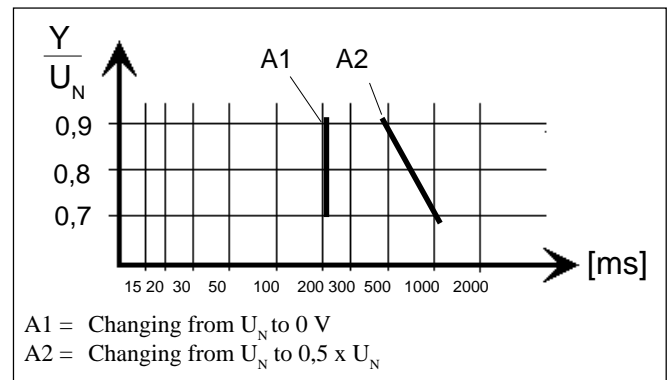

### Delay on release

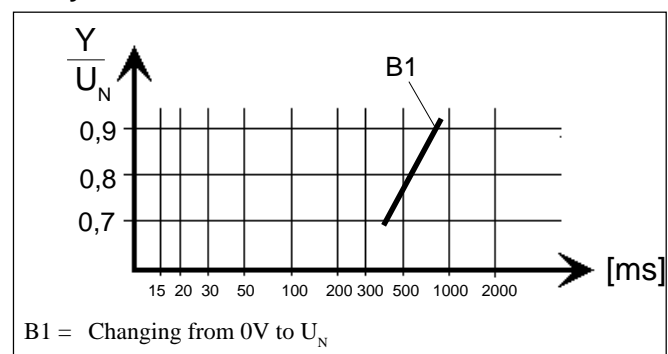

### Dimension diagram

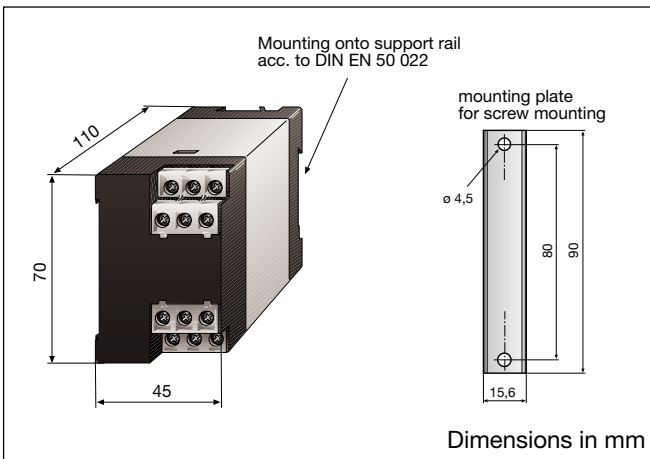

## Technical data SUD140

Insulation coordination acc. to IEC 664-1:	
Rated insulation voltage	AC 440 V
Rated impulse withstand voltage	
Contamination level	4 kV/3
Dielectric test acc. to IEC 255	2.5 kV
System being monitored	
Nominal voltage of the system $U_N$	3 / N AC 50...60 Hz 100/58 ... 115/66 V 200/115 ... 220/127 V 380/220 ... 440/254 V
Operating range	0 ... 1.15 x $U_N$
Supply voltage	
Supplied by the system being monitored	
Self-consumption	2.5 VA
Response values	
Response value adjustable	40 ... 60 V, 80 ... 120 V or 160 ... 240 V
Repeat accuracy	1.5 %
Temperature influence	< 0.05 % / °C
Frequency influence	< 0.1 % / Hz
Switching hysteresis approx.	5 %
Contact circuit	
Switching components	2 change over contacts
Contact class acc. to DIN IEC 255 Teil 0-20	IIB
Rated contact voltage	AC 250 V/DC 300 V
Admissible number of operations	12000 cycles
Limited making capacity	UC 5 A
Limited breaking capacity	
at AC 230 V and $\cos \phi = 0.4$	AC 2 A
at DC 220 V and $L/R = 0.04$ s	DC 0.2 A
Operating principle	N/C operation
Type tests	
Test of the Electromagnetic Compatibility (EMC):	
Immunity against electromagnetic Interferences acc. prEN 50082-2:	
Impulse voltage and electrical disturbance test acc. to IEC 255:	
Impulse voltage test acc. to IEC 255-5	class III
Electrical disturbance test acc. to IEC 255-5	class III
Emissions acc. to EN 50081-2:	
Emissions acc. to EN 55011/CISPR11	class B <sup>1)</sup>
Mechanical tests:	
Shock resistance acc. to IEC 68-2-27	15 g/11 ms
Bumping acc. to IEC 68-2-29	40 g/6 ms
Vibration strength acc. to IEC 68-2-6	10 ... 150 Hz/0.15 mm - 2 g
Environmental conditions	
Ambient temperature, during operation	-15°C ... +50°C
Storage temperature range	-20°C ... +70°C
Climatic class acc. to IEC 721	3K5, except condensation and formation of ice
General data	
Operation class	continuous operation
Mounting position	any position
Type of connection	terminal screws with self-lifting clamp-washers
Wire cross section	
single wire	2 x (1...1,5 mm <sup>2</sup> ) 16 AWG
fine braid	2 x (0,75...1,5 mm <sup>2</sup> ) 16 AWG
DIN rail	according to DIN EN 50 022 or screw mounting
Protection class acc. to EN 60529	
Internal components	IP 50
Terminals/with terminal covers	IP10/IP 20
Type of casing	X140
Flammability class	UL94V-0
Weight	approx. 300 g

<sup>1)</sup> Class B devices are suitable for household and industrial use.

## Wiring diagram

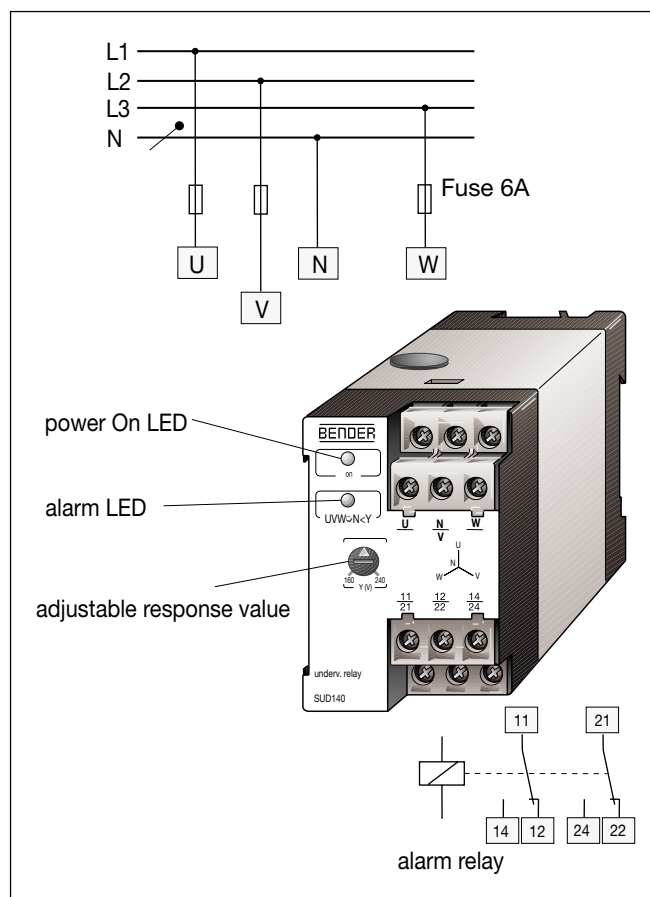

## Safety instructions

Please check for correct mains voltage!

Electrical equipment shall only be installed by qualified personnel in consideration of the current safety regulations.

For short-circuit protection, the network coupling has to be equipped with a protective device according to IEC 364-4-473 (A fuse of 6 A is recommended).

Supplementary to this data sheet you will find enclosed "important safety instructions on the proper use of BENDER products."

## Ordering details

Type	Rated system voltage	Response value	Art.-No.
SUD140	3/N AC 100...115 V	40...60 V	933 556
	3/N AC 200...220 V	80...120 V	933 504
	3/N AC 380...440 V	160...240 V	933 505

Other values on request

## Ordering details for screw mounting

Type	Art. No.
Mounting plate	300 102

## BENDER Industrial Products

700 Fox Chase, Coatesville PA 19320  
Tel. (800) 356-4266 Fax. (610) 383-7100  
www.benderrelay.com