

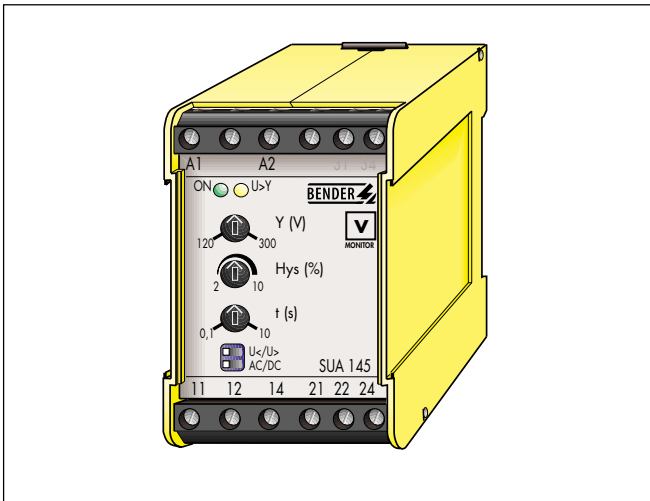

- Single Phase Circuits
- AC or DC Systems (Selectable)



- electronic measuring relay for AC and DC voltages
- signals overvoltage or undervoltage
- additional supply voltage is not required
- alarm relay with two change-over contacts
- built-in power on and alarm LEDs
- compact 45 mm housing
- adjustable: response value, response time, hysteresis
- built-in energy storage
- opto - coupler output optional (SUA145-1)

Function

1. Use as an overvoltage relay

The alarm relay K1 operates in N/O operation and the alarm LED „U>Y“ does not light up.

If the set response value “Y” is exceeded, the yellow alarm LED “U>Y” lights up and the alarm relay K1 operates after the expiry of the set response time delay “t”. Option with optocoupler (SUA145-1): optocoupler is in conducting state (terminals 31/34).

If the actual value falls below the set response value including the hysteresis “Hys”, the alarm relay releases and the yellow alarm LED is extinguished after the expiry of the delay on release of about 450 ms.

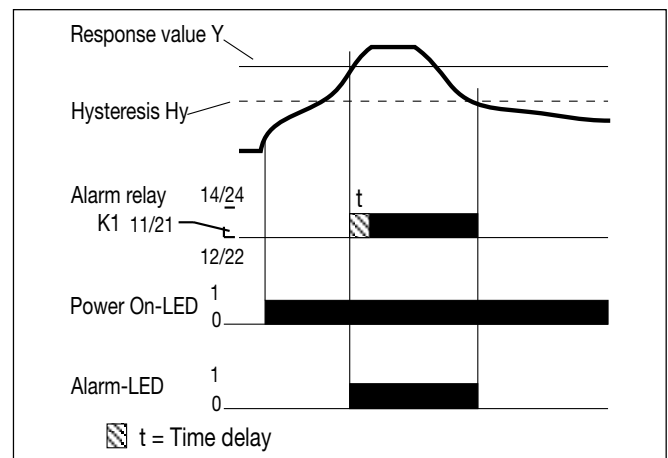

2. Use as an under voltage relay

The alarm relay K1 operates in N/C operation and the alarm LED “U>Y” lights up.

If the actual value falls below the set response value „Y“, the yellow alarm LED „U>Y“ is extinguished and the alarm relay K1 releases after the expiry of the set delay on response „t“. Option with opto-coupler (SUA145-1): opto-coupler is in blocking state (terminals 31/34).

If the set response value is exceeded including the hysteresis “Hys”, the alarm relay operates out and the yellow alarm LED illuminates after expiry of the delay on release of about 450 ms.

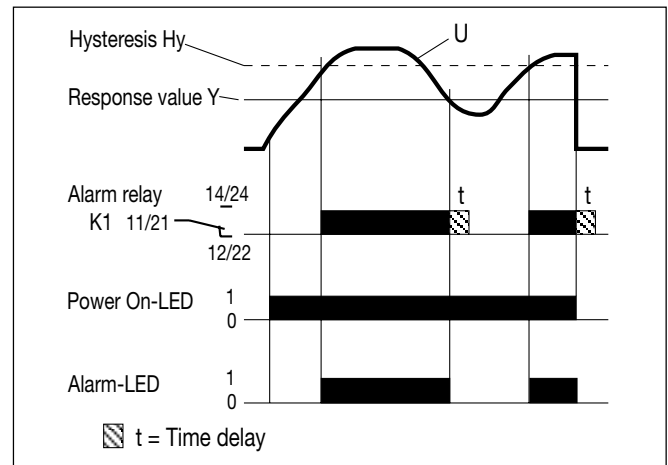

Dimension diagram

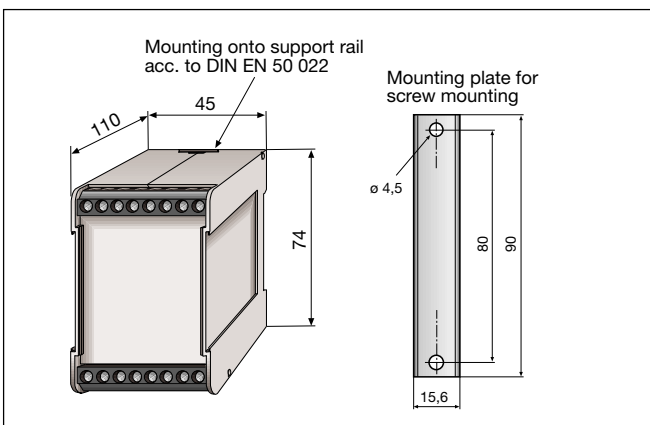

Technical data SUA145

Monitored System	
Nominal system voltage U_N	DC or AC 40...400 Hz
Operating range	response range
10...35 V	10 ... 30 V
20...275 V	20 ... 60 V (opto)
50...275 V	50 ... 150 V
120...350 V (440V / 5 min.)	120 ... 300 V
Power consumption max.	3.5 VA

Response values	
Response value	see Order details
Repeat accuracy	1.5 %
Influence of ambient temperature	<0.11% / °C
Switching hysteresis (steplessly adjustable)	2...10 %
Delay on response, (steplessly adjustable)	0.1...10 sec.
Built-in energy storage	
10...30 V	min. 1 sec.
20...60 V (opto)	min. 1.5 sec.
50...150 V, 120...300 V	min. 6 sec.
Delay on release	ca. 450 ms
Recovery time	ca. 1.5 sec.
Charging time for energy storage	ca. 60 sec.
Operating mode (for undervoltage operation)	N/C operation
Operating mode (for overvoltage operation)	N/O operation
Pre-set by factory	Under voltage relay, AC-operation

Contact circuit	
Alarm relays	2 change over dry contacts
Contact class acc. to DIN IEC 60255 Teil 0-20	IIB
Rated contact voltage	AC 250 V/DC 300 V
Admissible number of operations	12000 cycles
Making capacity	UC 5 A
Breaking capacity	
at AC 230 V and $\cos \phi = 0.4$	AC 2 A
at DC 220 V and $L/R = 0.04$ s	DC 0.2 A
Optocoupler	Umax. AC 140 V / DC 200 V Ulow (30 mA): <0.5 V

Type tests	
Test of the Electromagnetic Compatibility (EMC)	
Interferences acc. prEN 50082-2	
Emissions acc. to EN 50081-1 (only for industrial use)	
Mechanical tests	
Shock resistance acc. to IEC 6068-2-27	15g / 11 ms
Bumping acc. to IEC 6068-2-29	40g / 6 ms
Vibration strength acc. to IEC 6068-2-6	10...150 Hz / 0.15 mm - 2g

Environmental conditions	
Ambient temperature, during operation	-15°C...+55°C
Storage temperature range	-40°C...+70°
Climatic class acc. to IEC 60721	3K5, except condensation and formation of ice

General data	
Operation class	continuous operation
Mounting	any position
Type of connection	Terminal block
Wire cross section	
single wire	0.2 ... 4 mm ²
fine braid	0.2 ... 2.5 mm ²
	AWG 24 - 12
Rapid mounting	DIN Rail or screw mounting
Protection class acc. to EN 60529	
Internal components	IP 30
Terminals/with terminal covers	IP 20
Type of casing	XM45
Flammability class	UL94V-0
Weight	approx. 210 g

Wiring diagram

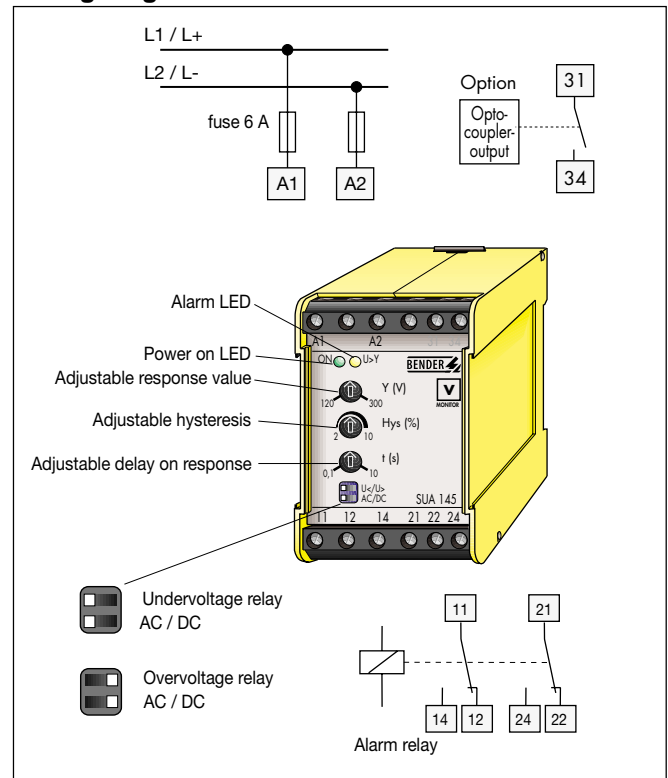

Safety instructions

Please check for correct mains voltage !

Electrical equipment is to be installed or assembled only by qualified electricians. The relevant safety precautions must be observed.

The power supply connection is to be provided with protective devices in accordance with IEC 364-4-473 to protect against short-circuit (a 6 A fuse is recommended).

In addition to this data sheet, you will find enclosed the "Important safety instructions for BENDER products" which form a constituent part of the device documentation.

Ordering details

Type	Response value UC	Art. No.
SUA145	10 - 30 V	B 9301 5508
	20 - 60 V	B 9301 5509
	50 - 150 V	B 9301 5510
	120 - 300 V	B 9301 5511
SUA145-1	20 - 60 V Opto	B 9301 5507

Ordering details for screw mounting:

Type	Art. No.
Mounting plate	300102

BENDER Industrial Products

700 Fox Chase, Coatesville PA 19320
Tel. (800) 356-4266 - Fax. (610) 383-7100
www.benderrelay.com